



**INSTALLATION  
AND  
OPERATING  
INSTRUCTIONS**

**Model: VH1828G**

**COUNTERTOP MODEL  
GAS IMPINGEMENT CONVEYOR OVEN**

**INTENDED FOR OTHER THAN HOUSEHOLD USE**

**RETAIN THIS MANUAL FOR FUTURE REFERENCE  
OVEN MUST BE KEPT CLEAR OF COMBUSTIBLES AT ALL TIMES**



**FOR YOUR SAFETY:** Do not store or use gasoline or other flammable vapors and liquids in the vicinity of this or any other appliance.



**WARNING:** Improper installation, adjustment, alteration, service or maintenance can cause property damage, injury or death. Read the Installation, Operating and Maintenance Instructions thoroughly before installing or servicing this equipment.



Initial heating of oven may generate smoke or fumes and must be done in a well ventilated area. Overexposure to smoke or fumes may cause nausea or dizziness.

This equipment has been engineered to provide you with year-round dependable service when used according to the instructions in this manual and standard commercial kitchen practices.



ANSI/NSF4

**BAKERS PRIDE OVEN CO., INC.**

30 Pine Street  
New Rochelle, NY 10801

P/N U4174A 3/07

+1 (914) 576-0200 Phone  
+1 (914) 576-0605 Fax

(800) 431-2745 US & Canada  
www.bakerspride.com Web Address  
info@bakerspride.com e-mail Address



**Bakers Pride** takes pride in the design and quality of our products. When used as intended and with proper care and maintenance, you will experience years of reliable operation from this equipment. To ensure best results, it is important that you carefully read and follow the instructions in this manual.









Installation and start-up should be performed by a qualified installer who has thoroughly read, understands and follows these instructions.

If you have questions concerning the installation, operation, maintenance or service of this product, contact our Technical Service Department at (800) 431-2745.

## 1. SAFETY PRECAUTIONS













Before installing and operating this equipment be sure everyone involved in its operation are fully trained and are aware of all precautions. Accidents and problems can result by a failure to follow fundamental rules and precautions.

The following words and symbols, found in this manual, alert you to hazards to the operator, service personnel or the equipment. The words are defined as follows:

- |  |  |  |
|--|--|--|
|   | <b>DANGER:</b> This symbol warns of imminent hazard which will result in serious injury or death.  |   |
|   | <b>WARNING:</b> This symbol refers to a potential hazard or unsafe practice, which could result in serious injury or death.                              |   |
|   | <b>CAUTION:</b> This symbol refers to a potential hazard or unsafe practice, which may result in minor or moderate injury or product or property damage. |   |
|  | <b>NOTICE:</b> This symbol refers to information that needs special attention or must be fully understood even though not dangerous.                     |  |

## 2. GENERAL INFORMATION

### THIS MANUAL SHOULD BE RETAINED FOR FUTURE REFERENCE

- |   |  |   |
|---|--|---|
|  | <b>CAUTION:</b> These models are designed, built, and sold for commercial use. If these models are positioned so the general public can use the equipment make sure that cautions, warnings, and operating instructions are clearly posted near each unit so that anyone using the equipment will use it correctly and not injure themselves or harm the equipment.  |  |
|  | <b>WARNING:</b> Check the data plate on this unit before installation. Connect the unit only to the voltage and frequency listed on the data plate. Connect only to 1 or 3 phase as listed on the data plate.  |  |
|  | <b>WARNING:</b> Electrical and grounding connections must comply with the applicable portions of the national electrical code and/or other local electrical codes.   |  |
|  | <b>WARNING:</b> Disconnect device from electrical power supply and place a Tag Out-Lockout on the power plug, indicating that you are working on the circuit.  |  |
|  | <b>WARNING:</b> Install per the spacing requirements listed in the installation section of this manual. We strongly recommend having a competent professional install the equipment. A licensed electrician should make the electrical connections and connect power to the unit. Local codes should always be used when connecting these units to electrical power. In the absence of local codes, use the latest version of the National Electrical Code.              |  |
|  | <b>WARNING:</b> This device should be safely and adequately grounded in accordance with local codes, or in the absence of local codes, with the National Electrical code, ANSI/NFPA 70, Latest Edition to protect the user from electrical shock. It requires a grounded system and a dedicated circuit, protected by a fuse or circuit breaker of proper size and rating. Canadian installation must comply with the Canadian Electrical Code, CSA C22.2, as applicable |  |



**WARNING:** A factory authorized agent should handle all maintenance and repair. Before doing any maintenance or repair, contact Bakers Pride.



**WARNING:** Never clean any electrical unit by immersing it in water. Turn off before cleaning surface.



**WARNING:** An earthing cable must connect the appliance to all other units in the complete installation and from there to an independent earth connection.



**NOTICE:** The unit when installed, must be electrically grounded and comply with local codes, or in the absence of local codes, with the national electrical code ANSI/NFPA70- latest edition. Canadian installation must comply with CSA-STANDARD C.22.2 Number 0 M1982 General Requirements-Canadian Electrical Code Part II, 109-M1981- Commercial Cooking Appliances.



**WARNING: SHOCK HAZARD -** De-energize all power to equipment before cleaning the equipment.



**NOTICE:** Local codes regarding installation vary greatly from one area to another. The National Fire Protection Association, Inc. states in its NFPA96 latest edition that local codes are "Authority Having Jurisdiction" when it comes to requirements for installation of equipment. Therefore, installation should comply with all local codes.



**WARNING:** In Europe, appliance must be connected by an earthing cable to all other units in the complete installation and thence to an independent earth connection in compliance with EN 60335-1 and/or local codes



**WARNING:** For Propane gas, use at least 1/2" (13 mm) pipe or tubing with a 5/8" (16 mm) inside diameter. For Natural gas, use 3/4" (19 mm) pipe.



**WARNING:** Use a pipe joint compound that is resistant to the action of liquefied petroleum gases when making gas connections.



**WARNING:** The appliance must be isolated from the gas supply piping system by closing its manual shut-off valve during any pressure testing of the gas supply piping system at test pressures equal to or less than 1/2" psig (3.45kpa).



**WARNING:** The appliance and its shut-off valve must be disconnected from the gas supply piping system during any pressure testing of that system at test pressures in excess of 1/2" psig (3.45kpa).



**WARNING:** A separate shut-off valve for each appliance must be provided. It should be as close as possible to the place where the gas supply line goes into the appliance. It must be located such that it is easily accessible.



**WARNING:** When stacking with another oven, two shut-off valves, one for each of the two ovens, must be provided.



**WARNING:** After the Gas Supply has been connected, it is extremely important to check all the piping for leaks. Use a soap and water solution or a product expressly made for this purpose. Do not use Matches, Candles or a flame etc to check leaks since these methods are extremely dangerous.



**WARNING:** If gas odor is detected at any time, immediately shut-off the gas supply valve for the appliance. Do not permit any open flames in the area of the appliance. Immediately contact an authorized Service Agency or your local Gas Supply Company.



**WARNING:** Initial heating of the appliance must be done in a well-ventilated area as it may generate smoke or fumes. Over exposure to smoke or fumes may cause nausea or dizziness



- NOTICE:** Instructions to be followed if anyone smells gas should be posted in a prominent place. These may be obtained from the gas supplier.
- WARNING:** Post in a prominent location instructions to be followed in the event you smell gas. Obtain these instructions from your local gas supplier.
- NOTICE:** Installation must conform with local codes and/or to the latest edition of the ANS Z-223.1 National Fuel Gas Code in USA ( CAN/CGA-B 149.1 or 2 Installation Code in Canada).
- NOTICE:** This equipment has been engineered to provide you with year round dependable service when used according to the instructions in this manual and standard commercial kitchen practices.
- WARNING:** Do not use oven cleaners, caustic solutions or mechanical means to clean the appliance as they will damage the interior aluminized surface.
- WARNING: This appliance must be serviced by an Authorized Service Technician only. Disconnect the power supply before cleaning or servicing the oven.**  
 Regular and thorough cleaning will help to keep the ovens operating properly. If service is required, contact an Authorized Service Agency, your dealer or the factory to obtain a qualified technician for the required maintenance/service.
- CAUTION:** This product when stacked, has more than one power supply connection point. Disconnect all power supplies before servicing.
- WARNING: SHOCK HAZARD -** Do not open any panels that require the use of tools.
- WARNING:** Neglecting to keep fan opening clean could result in control failure.
- WARNING:** Failure to provide clearances will cause unit failure and invalidate warranty claims (see installation instructions).

### IMPORTANT FOR FUTURE REFERENCE

Please complete this information and retain this manual for the life of the equipment. For Warranty Service and/or Parts, this information is required.

_____	_____	_____
Model Number	Serial Number	Date Purchased

Models Covered	Total KW	Phase
VH1828G	1.0	1

### 3. RECEIVING

Read the notice on the outside carton regarding damage in transit. "CONCEALED DAMAGE", damage discovered after opening the crate(s), MUST be reported immediately to the carrier. The carrier will perform an inspection of the damage and furnish forms for the consignee's claim against the carrier. Retain ALL packaging material - including outer carton, until the inspection has been completed.

Proper and secure storage facilities should be arranged for the conveyor oven(s) if necessary to protect it from outdoor or damp conditions at all times prior to installation.

## 4. LOCATION AND MINIMUM CLEARANCES

Adequate air space must be provided for the proper venting of the rear exhaust air and provision made for venting of cooking vapors. The Conveyor Oven must be installed in a well-ventilated area.

*NOTE:* Attached rear rubber bumpers must not be removed and can contact a rear wall if present.

Conveyor Ovens can be installed with "ZERO" clearances (back and sides) from combustible and non-combustible materials. (Rear rubber bumpers are the "Zero" clearance points on the back of the unit.) See rating plate attached to the control box door panel.

The Conveyor Oven is intended for countertop mounting if mounted on the 4" legs provided. The Oven is NOT approved for mounting on any floor. Keep the area around your conveyor oven free and clear of all combustible materials.

## 5. INSTALLATION

**In MASSACHUSETTS:** All gas products must be installed by a "Massachusetts" licensed plumber or gas fitter. Ventilation hoods must be installed in accordance with NFPA-96, current edition, with interlocks as described in that standard.

Place the conveyor oven and parts as close to the area of final installation before uncrating. Your conveyor oven is packed sitting on its bottom. Leave it this way until unpacked. The pallet may be left under the conveyor oven for convenience in further handling. Unpack carefully to avoid damage to the unit. If concealed damage is discovered, follow the instructions detailed in Section 1 above.

### ***DO NOT LIFT EXCESSIVE WEIGHT***

- A. Legs are shipped unattached. Make sure each leg is attached and tightened before placing the conveyor oven in place. Each leg is adjustable to accommodate variations in the mounting surface.
- B. Using sufficient help (2 or more people), lift the conveyor oven upward and place on the countertop surface. Lift the conveyor oven by gripping the bottom of the unit. **THE FOLLOWING ITEMS ARE NOT TO BE USED AS LIFTING "HANDLES":** Side-mounted control boxes (2), front door, the conveyor belt assembly, the rear fan housing assembly.
- C. ***THE CONVEYOR BELT ASSEMBLY IS MOUNTED BACKWARDS FOR SHIPPING. THE CONVEYOR BELT ASSEMBLY MUST BE REMOVED AND REVERSED PRIOR TO OPERATION.*** See Section 9a, b for further instructions.
- D. Position the conveyor oven in its final location, maintaining the minimum clearances specified in Section 4 above.
- E. Remove all loose parts and packages from the interior of the conveyor oven. The conveyor oven has (4) air-directing "plenum fingers" in the interior cooking chamber. Check these items for proper mounting. For further information on removal and mounting of interior panels, see Section 13, cleaning.

## 6. STACKING

Your conveyor oven(s) can be stacked up to (3) high. Each unit is built exactly the same, so it does not matter in which order they are stacked. For stacking of (2) units, remove the legs from the second (upper) unit prior to mounting on top of the bottom unit. For stacking of (3) units, it is preferable to use a "stacking kit", which allows all conveyor ovens to be supported by an external framework, such as a table, with each conveyor oven having all legs removed.

*"CAUTION: If you use a multiple stack assembly, remember that each oven has its own power disconnect. Make sure ALL main switches are OFF before any cleaning or maintenance is performed."*

When stacking, remove legs from upper unit.

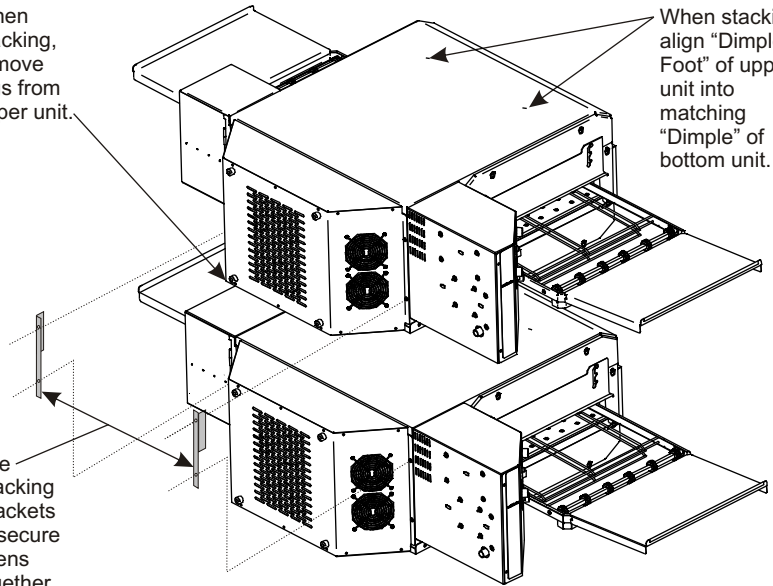

1. Remove two bottom screws from the top oven rear panel.
2. Remove two top screws from the bottom oven rear panel.
3. Install the right and left stacking brackets as shown in above diagram.
4. Reinstall the four removed screws.

## 7. ELECTRICAL CONNECTIONS

### General Instructions

- a) Model 1828G ovens are supplied with a flexible power cord and plug.
- b) Make sure the electrical supply corresponds with that specified on the rating plate (see section 15).
- c) Wiring diagrams are located in the Installation/Operating Instructions.
- d) When installed, the unit must be electrically grounded in accordance with the local codes and/or the latest edition of the national Electrical Code ANSI/NFPA No. 70 in the USA or Canadian Electrical Code, CSA Standard C22.1, Part 1 in Canada.

### NEMA SPECS.

NEMA 5-15

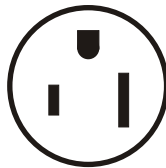

**WARNING:** Initial heating of oven may generate smoke or fumes and must be done in a well ventilated area. Overexposure to smoke or fumes may cause nausea or dizziness.



**EACH OVEN REQUIRES A SEPARATE CONNECTION**



**CAUTION:** Normal cooking operations may result in the production of smoke or fumes and may cause nausea and dizziness. Be sure the oven is placed in a well-ventilated area.



## 8. GAS CONNECTIONS

The 1828G conveyor oven can be ordered either as Natural Gas or Liquid Propane Gas.

- A) Only a qualified gas appliance installer should make gas connections.
- B) The 1828G is supplied with a ½" NPT inlet pipe only. The installer must supply an approved external gas pressure regulator to limit the inlet gas to the following pressure settings:
  - Natural Gas: 4" W.C.
  - Propane Gas: 10" W.C.
- C) The installer must also supply a separate shut-off valve between the gas supply and the appliance gas regulator.
- D) If a flexible gas supply line is used, it must be connected as shown in the diagram below. The flexible connection must allow for movement without causing kinks in the hose. A sufficient restraining device must also be attached to any portable mounting device to prevent the hose from becoming overextended.

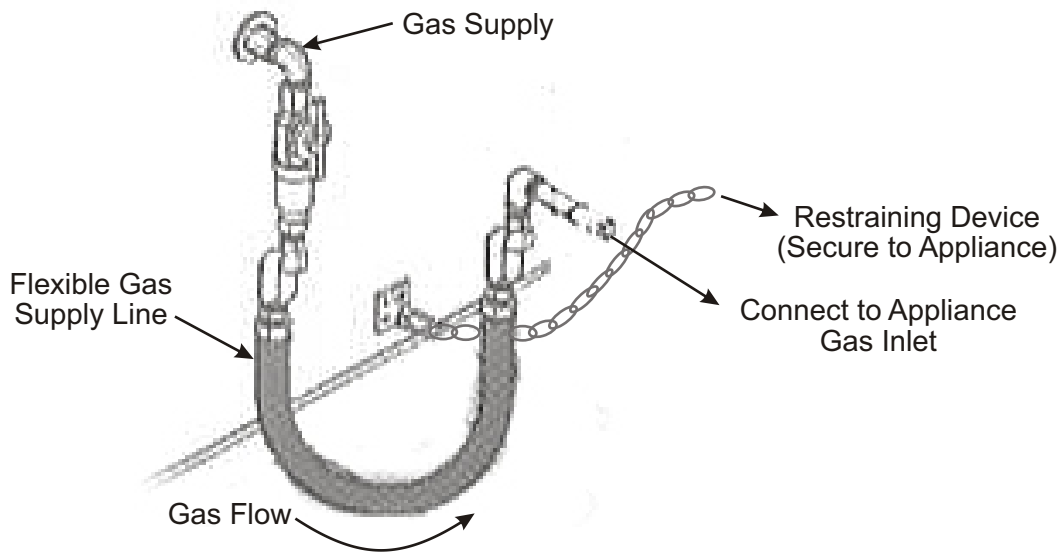



## 9. SYSTEM CHECK

A) Insure that the conveyor belt assembly is installed correctly, with the drive-shaft pin fitting firmly into the coupling that protrudes from the Power Control Box gearmotor output shaft. Visually check that the belt is flat and parallel to the countertop surface. If the belt is not parallel to the countertop, it may be necessary to re-align the gearmotor output shaft to the conveyor belt drive shaft pin. Follow this procedure:

1. **DISCONNECT THE POWER SUPPLY BEFORE SERVICING COMPONENTS INSIDE EITHER OF THE CONTROL BOXES. SERIOUS INJURY, INCLUDING DEATH, MAY OCCUR IF CONTACT IS MADE TO INCOMING POWER.**
2. Re-aligning the coupling / driven-shaft pin requires opening the Power Control Box door.
3. Insert a hex-head nut-driver tool to loosen the (4) screws that fasten the gearmotor to the box side panel.
4. Re-align the coupling to the conveyor belt drive shaft pin. If this is done properly, the driven-shaft pin will fit snugly into the slot of the gearmotor coupling.
5. When alignment is correct, re-tighten the (4) screws at the gearmotor before closing the door.

B) The conveyor belt is capable of traveling either Left-to-Right (standard), or Right-to-Left (optional). Direction of travel is determined by looking at the conveyor oven from the front of the unit. Direction of travel is controlled by a "Reversing Switch" that is located inside the control box containing the gearmotor. If the direction of travel needs to be reversed, follow this procedure:

**NOTE: CHANGE THE REVERSING SWITCH ONLY WHEN POWER IS DIS-CONNECTED TO THE CONVEYOR OVEN. OTHERWISE, FATAL DAMAGE WILL OCCUR TO THE GEARMOTOR, CAUSING THE CONVEYOR BELT TO STOP MOVING. THE GEARMOTOR WILL NEED TO BE REPLACED DUE TO INTERNAL STRUCTURAL DAMAGE.**

1. **DISCONNECT THE POWER SUPPLY BEFORE SERVICING COMPONENTS INSIDE EITHER OF THE CONTROL BOXES. SERIOUS INJURY, INCLUDING DEATH, MAY OCCUR IF CONTACT IS MADE TO INCOMING POWER.**
2. Reversing the conveyor belt requires opening the Power Control Box door.
3. Locate a small rocker switch mounted just inside the control box. Two wires are connected to it.
4. Change the switch position to the opposite setting. No other changes are necessary.
5. Close and securely fasten the door.
6. Re-connect power to the unit.

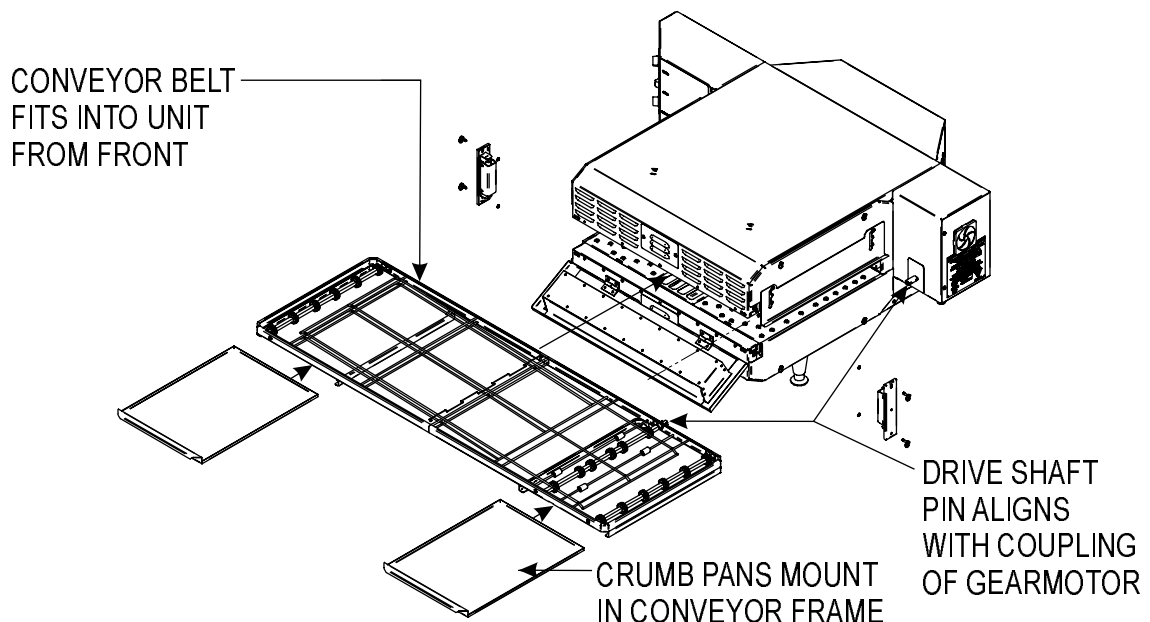

- C) Open the front door and verify the proper orientation of the upper air return shield. **The plenum fingers are identical, so any finger can be mounted in any location.**
- D) Close the front door into the front opening, sealing the cooking chamber closed. Secure the (4) outer side panels to the main frame assembly using the 1/4-turn fasteners that are attached to these panels. Mount these side panels AFTER the conveyor has been properly installed. Adjust the outer baffles UP / DOWN until they are in the correct position to allow product to enter and exit with minimal vertical clearance. This will reduce the amount of heat lost out the sides of the cook chamber.

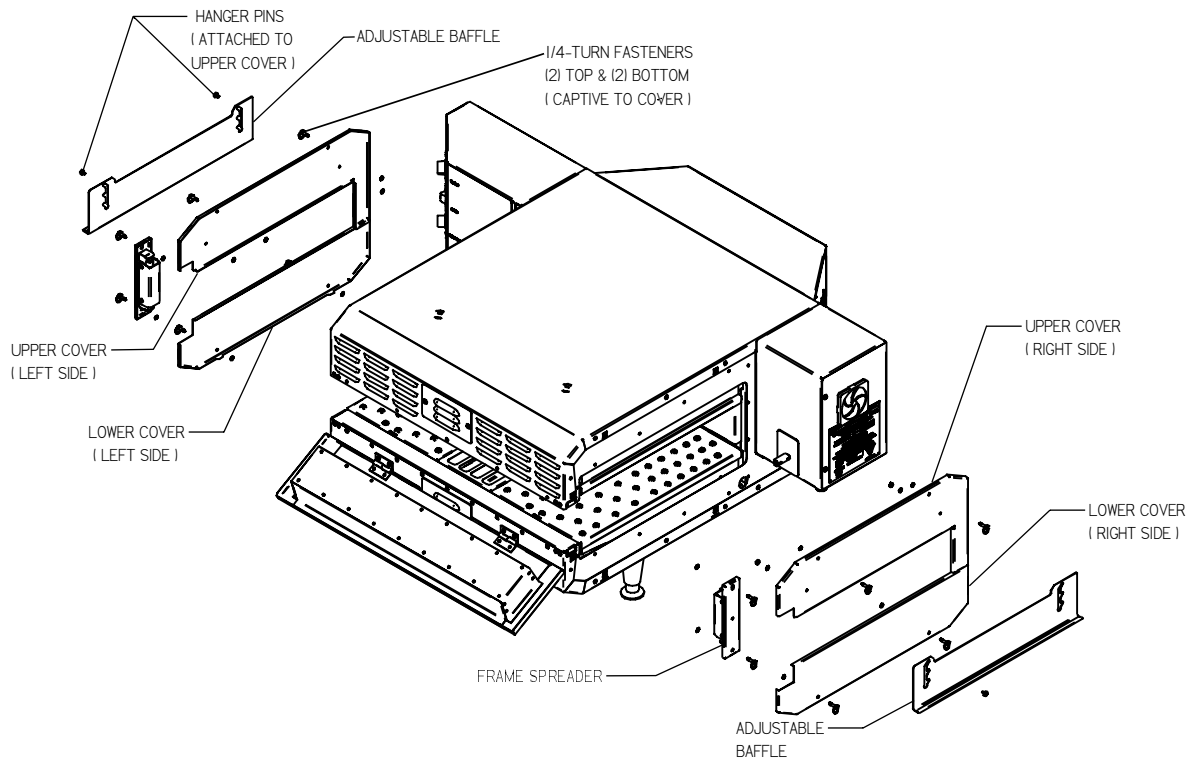

## 10. INITIAL STARTUP

- A) Focus on the angled Gas Control Box containing the Main Switch (GREEN rocker type, lighted). The VH-Series oven contains (3) adjustable knobs for temperature controls and conveyor belt speed. Two indicator lights are mounted to show when HEAT is being added to the system.

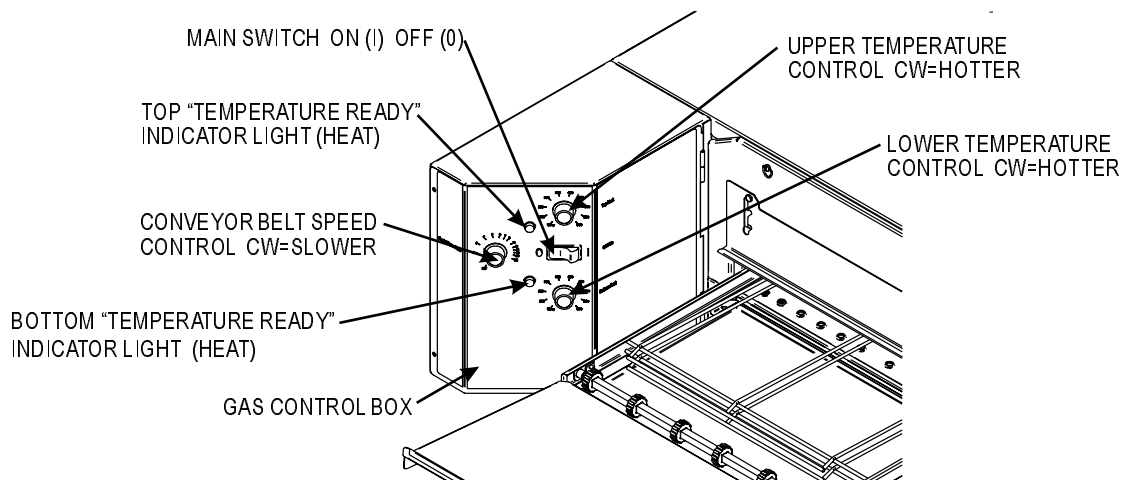

- 1) Flip ON the Main Switch. The switch should light up when ON ( I ), and be dark when OFF(O). Normal warm-up time is 30-40 minutes for maximum temperature. Lower temperature settings will take less time.
- 2) Set the Temperature Controls to MAX (full Clockwise rotation). The Indicator Lights will illuminate because there is not sufficient heat in the oven. The lights tell you that the burners are ON.
- 3) Turn the temperature control knobs to 350°F. As each chamber (upper and lower) reach this temperature, the indicator lights will cycle ON and OFF, verifying that the burners are operating properly in response to heat demand.
- 4) As you become familiar with the oven, you will set the Top and Bottom Temperature Controls to different settings, according to your cooking requirements. As the oven temperatures vary, the Indicator Lights will turn ON and OFF as the heaters respond to the cooking process.
- 5) Gradually turn the conveyor belt control Counter-clockwise and verify that the conveyor belt moves faster and faster. Repeat this process, turning the knob Clockwise, verifying that the conveyor belt moves slower.

**NOTE:** AT SPEED SETTINGS ABOVE “10” (10-minute cook time), IT MAY BE HARD TO TELL THE BELT IS MOVING. PLACE A PAN ON THE BELT TO OBSERVE THAT IT MOVES INTO THE COOK CHAMBER.

## 11. SHUTDOWN

The conveyor oven is supplied with a special “COOL-DOWN CIRCUIT” that helps cool the oven quickly once the unit has been shut OFF. This feature performs the following functions when the Main Switch is turned OFF at the end of the day:

- a) The blowers keep running to re-circulate air through the air plenums.
- b) The gas burners shut OFF.
- c) The conveyor belt stops moving.
- d) Once the oven has cooled down to a factory pre-set temperature, the blowers shut OFF. The oven is now completely OFF. **NOTE: This pre-set temperature is not adjustable.**

**NOTE: TO ACCELERATE THE COOLING OF THE OVEN, OPEN (LOWER) THE HINGED FRONT DOOR TO ALLOW COOLER AIR INTO THE SYSTEM.**

**NOTE: IF THE MAIN SWITCH IS TURNED BACK ON WHILE THE UNIT IS COOLING DOWN, THE BURNERS, BLOWERS AND CONVEYOR BELT WILL RE-ENGAGE TO BEGIN STANDARD COOKING OPERATION. THIS IS NORMAL AND WILL NOT DAMAGE THE OVEN. HOWEVER, THE UNIT WILL NEVER GET HOT ENOUGH TO COOK IF THE HINGED FRONT DOOR REMAINS OPEN.**

## 12. SPECIAL FEATURES

Your new conveyor oven has been built with numerous enhancements to add flexibility and simplicity to your cooking operation.

### VARIABLE HEAT/FIXED AIR

- A. INDEPENDENT TOP AND BOTTOM HEAT. Different temperature settings can be set for both top and bottom heat zones.
- B. VARIABLE-SPEED CONVEYOR BELT
- C. FIELD-REVERSIBLE CONVEYOR BELT TRAVEL
- D. FRONT-REMOVABLE CONVEYOR BELT. No need to slide the belt assembly out the side.
- E. INDEPENDENT TOP AND BOTTOM OUTER SIDE COVERS. Makes it possible to remove conveyor belt from the front.
- F. EASE IN CLEANING. This is accomplished by easily removable components for access to the cook chamber, air plenum “fingers”, and conveyor belt assembly.

## 13. CLEANING

CAUTION: THE CONVEYOR OVEN CONTAINS ELECTRICAL COMPONENTS. TURN OFF THE OVEN AND DISCONNECT THE POWER BEFORE CLEANING BEGINS.

**DO NOT CLEAN THE CONVEYOR OVEN WITH A WATER JET. Use only a damp cloth.**

**WEEKLY CLEANING:**

1. Remove crumb pans. Remove conveyor belt assembly.
2. Remove plenum “finger” assemblies and disassemble for cleaning.

**Oven Exterior:** **CLEAN ONLY WHEN THE OVEN IS COOL.** Standard construction of the exterior is of stainless steel.

Deposits of baked-on splatter and grease, or discoloration may be removed by using any commercial cleaner recommended for stainless steel. Always rub with the grains and apply very light pressure. **Rinse with a MOIST, NOT SOAKING, cloth.**

**Oven Interior:** **CLEAN ONLY WHEN THE OVEN IS COLD.** Standard construction of the interior (cook chamber) is of aluminized steel, and requires care not to “over-clean” and scratch the surface.

**CAUTION: DO NOT USE OVEN CLEANERS, CAUSTIC SOLUTIONS OR MECHANICAL MEANS BECAUSE THESE WILL DAMAGE THE ALUMINIZED SURFACES.** Use only the detergent solutions and cleaners that meet national and/or local codes. Clean the walls of the cook chamber with a mild soap and water solution.

To clean the interior of the conveyor oven, it is necessary to lower the hinged front door, the (4) outer sides panels, the conveyor belt assembly, the (2) side frame spreaders and the (4) air plenum “fingers”.

## Conveyor Belt Assembly

### 1. CONVEYOR BELT STILL MOUNTED IN OVEN:

**NOTE: USE CARE IF CLEANING THE CONVEYOR BELT WHILE IT IS STILL MOUNTED IN THE OVEN. EXCESSIVE FORCE MAY PRODUCE AN OVERLOAD CONDITION THAT COULD DAMAGE THE GEARMOTOR AND CAUSE THE OVEN TO BE RENDERED UN-USABLE.**

Using a plastic abrasive pad, wipe the conveyor belt in a back-and-forth motion to remove baked-on product. Wipe clean with a hot, damp cloth.

### 2. CONVEYOR BELT REMOVED FROM OVEN:

Using a plastic abrasive pad, wipe the conveyor belt in a back-and-forth motion to remove baked-on product. Wipe clean with a hot, damp cloth.

**NOTE: IT IS NOT NECESSARY TO REMOVE THE BELT FROM THE FRAME ASSEMBLY FOR CLEANING.**

### 3. Check the belt links for any sign of damage. If any links are bent, use a needle-nose pliers to repair prior to re-installation into the unit.

## Plenum "Fingers"

The conveyor oven contains (4) plenum "fingers" that direct air onto the product surface while cooking. This 3-piece assembly comes apart for cleaning, as shown below:

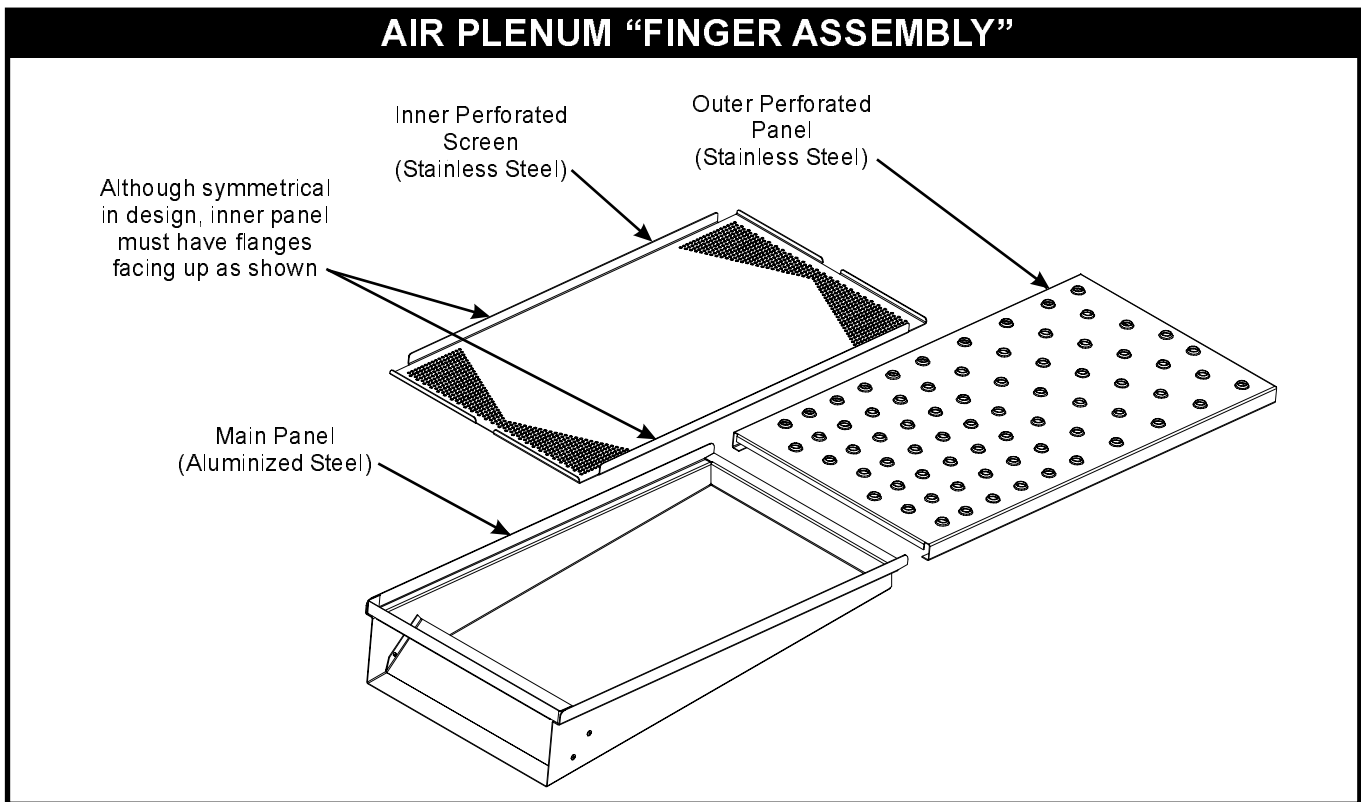

The Outer Perforated panel is locked into place through a friction fit to the Main panel. This method of fastening also captures the Inner panel, holding it in place. The Outer panel slides off the Main panel, exposing the perforated Inner panel. The Inner panel is symmetrical in design, and may be placed in either direction, as long as the outer flanges are pointing **UPWARD** as shown in the figure above.

The Inner and Outer panels are made of stainless steel, and therefore may be exposed to strong cleaners to remove baked-on grease, etc. Overnight soaking in a hot cleaning solution will improve the cleaning process.

The Main panel is made of aluminized steel like the main cook chamber, and thus requires the same level of care to retain its integrity. Follow the same precautions as mentioned above for the main cook chamber.

## 14. OPERATOR MAINTENANCE

**WARNING DANGER: DISCONNECT THE POWER SUPPLY BEFORE SERVICING OR CLEANING THE OVEN. SERIOUS INJURY, INCLUDING DEATH, MAY OCCUR IF CONTACT IS MADE WITH INCOMING POWER.**

During normal operation of the oven, lubrication is not required.

To achieve maximum efficiency, keep the oven clean. How you maintain your oven will determine how long it lasts.

If the oven fails to operate, perform the following inspections BEFORE calling an authorized service agent:

1. Check to see if the main circuit breaker is ON at the breaker panel.
2. Check the 10-amp fuse located in the bottom of the Power Control Box. **CAUTION: IF FUSE BAD, REPLACE ONLY WITH IDENTICAL FUSE. DO NOT SUBSTITUTE HIGHER VALUE FUSES, AS THIS MAY NULLIFY NEEDED PROTECTION FOR THE INTERNAL ELECTRICAL COMPONENTS.**
3. Check that the Main Switch is ON. If operating properly, the rocker switch will be lighted when ON.
4. Check the setting of the temperature control thermostats (knobs). If operating properly, they will activate the green indicator lights as you turn the knobs back and forth, calling for heat. It is very unlikely that the light will burn out.
5. If there is no air blowing, check the following:
  - A. **DUAL AIR MODEL VH-SERIES:** Observing the **WARNING** at the beginning of this section, open the Power Control Box and locate the overload relay (above gearmotor). **PUSH IN THE "RESET" BUTTON.** Try the Main Switch again.
    1. **NOTE: The Overload Relay is both a current limiting and a thermal device,** meaning that if one or both of the blower motors get jammed, the overload relay shuts the motor(s) OFF if there is excessive current going to the motor(s), or if excessive heat builds up in the overload relay due to an overload condition. Because it takes time for the relay to cool down, do not assume that there is another problem IF pushing the RESET button doesn't accomplish the task. Both settings, **RESET button pushed IN & overload not overheated,** must be correct for proper operation.
6. If the conveyor belt does not move, check to see that the coupling setscrew is tight on the gearmotor output shaft.



If the oven still does not operate, turn OFF the Main Switch and disconnect the power supply to the unit (if possible). Contact the factory, factory representative, or an authorized service agency.

**ALL SERVICING SHOULD BE PERFORMED ONLY BY A FACTORY AUTHORIZED SERVICE TECHNICIAN OR AGENT.**

7. Periodically check the tension of the conveyor belt. Adjust tension using the adjustment slots at the left end of the conveyor. Proper tension can be measured by the following: 6" from the left end of the conveyor, place fingers beneath belt and lift upwards. The belt should lift a maximum of 1 1/2", and a minimum of 1/2". If either of these are not possible using the adjustment slots, the length of the belt needs to be adjusted by either adding or deleting a link. A qualified service technician should perform this task.

## 15. RATING PLATE

A copy of the rating plate is shown here for reference.

BAKERS PRIDE OVEN CO. INC., NEW ROCHELLE, NY			
MODEL MODELE	SERIAL NO. NO. DE SERIE	DATE CODE CODE DE DATE	
INPUT RATE PER BURNER RENDEMENT HORAIRE EN BTU		B.T.U. PER HOUR PAR BRULEUR	Kw EN Kw
EQUIPPED FOR USE WITH GAS POUR USAGE AVEC GAZ		SEE GAS CODE BELOW VOIR CODE DE GAZ CI-BAS	
MANIFOLD PRESSURE / PRESSION D'ADMISSION			
NATURAL GAS / GAZ NATUREL	A	w/c(G) E	mbar
PROPANE GAS / GAZ PROPANE	E	w/c(G) E	mbar
IMPORTANT			
INTENDED FOR OTHER THAN HOUSEHOLD USE. DESTINE A UN USAGE AUTRE QUE DOMESTIQUE.			
FOR USE IN NONCOMBUSTIBLE LOCATIONS ONLY. DOIT ETRE UTILISE SEULEMENT DANS DES ENDROITS INCOMBUSTIBLES.			
SUITABLE FOR INSTALLATION WITH LEGS OR CASTERS PROVIDED. CONVIENT POUR INSTALLATION AVEC LES PATTES OU LES ROULETTES FOURNIES.			
THIS UNIT TO BE USED ONLY WITH A SUITABLE EXHAUST HOOD. CET APPAREIL NE DOIT ETRE UTILISE QU' AVEC UNE HOTTE APPROPRIEE.			
CLEARANCE FROM NONCOMBUSTIBLE CONSTRUCTION - SIDES, BACK: 0 ESPACE LIBRE DE CONSTRUCTION INCOMBUSTIBLE - COTES / ARRIERE: 0			
GAS-FIRED 	ANS Z83.11- CSA - 1.8 - FOODSERVICE EQUIP.		
		ANSI / NSF 4 U1862A	

## 16. CONVEYOR REMOVAL

Extensive Engineering went into designing your oven for ease of cleaning. One SPECIAL FEATURE is the ability to remove the conveyor belt assembly straight out the front of the oven. Follow this procedure, using the diagram provided: (See drawing next page)

- a) Remove any extension trays present, rotating them upwards to clear the conveyor frame. Flanges on the trays hook around the ends of the frame.
- b) Remove the two crumb pans.
- c) Remove the upper outer side covers, which have the adjustable baffles attached with pins. The covers are held in place with hand-twist fasteners. Turn these fasteners 90° counterclockwise to loosen, and 90° clockwise to tighten.
- d) Remove the two vertical frame spreaders that support the top frame. These are held in place with 1/4-turn fasteners, identical to the outer covers.
- e) It is not necessary to remove the outer lower side covers.
- f) Lower the hinged front door.
- g) Carefully supporting both right and left sides of the conveyor, lift the front edge slightly and pull towards you, watching as the drive shaft pulls out of the gearmotor coupling.

## 17. CONVEYOR INSTALLATION

Installing the conveyor belt assembly is done in exact reverse order to it's removal. The MOST IMPORTANT POINT is to properly align the drive shaft pin with the gearmotor coupling. If the drive shaft pin must be wedged into place for installation, the coupling location needs to be adjusted. See Section 6a for this procedure. **DO NOT FORCE THE DRIVE PIN INTO THE COUPLING IF THEY DO NOT ALIGN.**

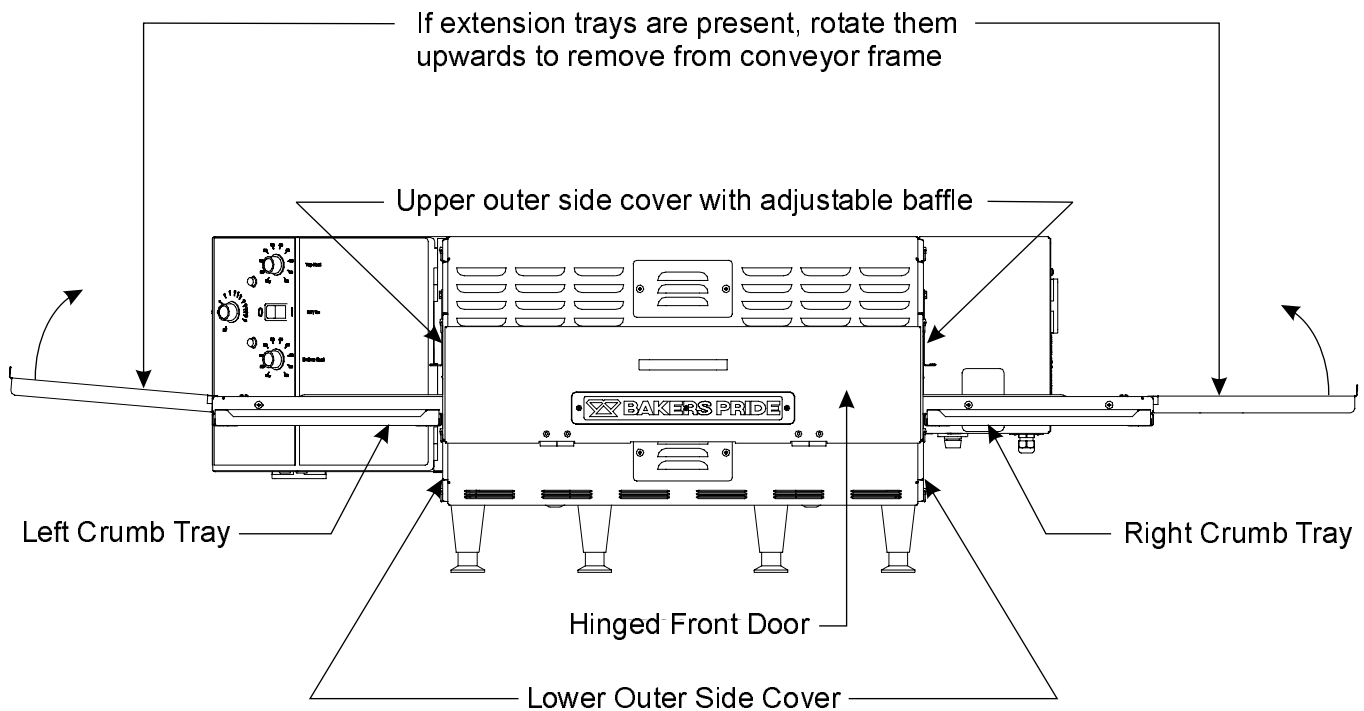

## 18. CONVEYOR BELT SPEED CALIBRATION

The conveyor belt requires calibration to properly align the speed control knob on the Gas Control Box. Calibration is done by timing the belt as it passes between two timing marks located on the conveyor frame. This method will work regardless of belt travel direction. Follow the instructions below.

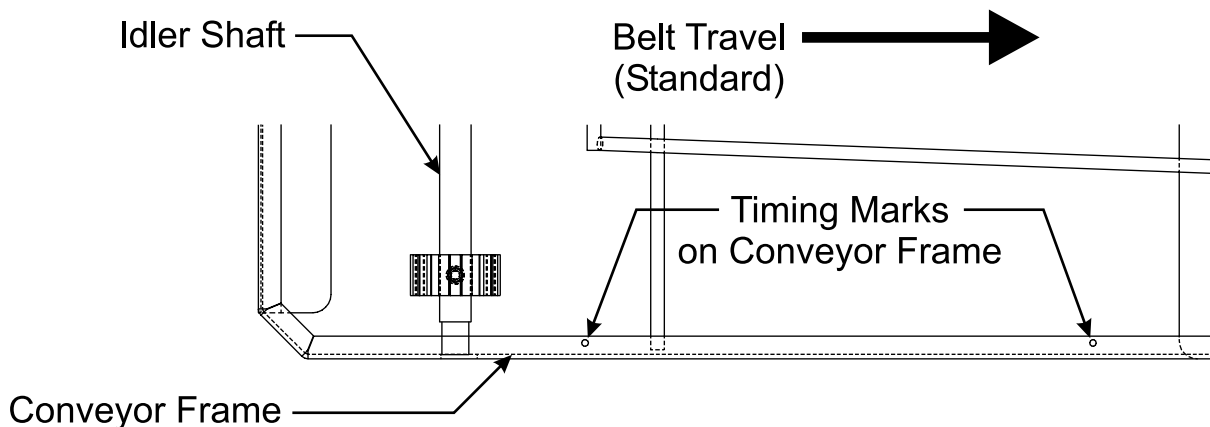

- A. Remove the adjustment knob of the conveyor belt speed control (see page 10) using a small, standard screwdriver to loosen the setscrew.
- B. Locate the two timing marks as shown. The marks are 7 inches apart. If the timing marks are NOT present, use a black marking pen to mark the frame in the same manner.
- C. These distances represent exactly  $\frac{1}{4}$  of the length of the cook chamber:  $\frac{1}{4} \times 28''$  cook chamber = 7".
- D. With this 1:4 ratio, it is possible to calibrate the belt speed. For example:
  1. For a cook time of 1 minute, the time required to pass between timing marks would be: 60 seconds / 4 = 15 seconds. If the belt passes from one mark to the next in 15 seconds, this is exactly the same as a 1-minute cook time.
  2. For a cook time of 6 minutes, the required time to pass between timing marks would be: 6 minutes x 60 seconds / 4. This equals 360 seconds / 4 = 90 seconds between marks. The belt needs to take 90 seconds (1-1/2 minutes) to move from one mark to the next to equal a 6-minute cook time.



- E. Using a black marking pen, mark any belt link near the outer edge. Using a stopwatch, check the time it takes for this link to move between the timing marks. Repeat this procedure several times until the distance is traveled in 90 seconds (recommended calibration interval), which equals a 6-minute cook time.
- F. Now that the belt is moving at this calibrated speed, CAREFULLY re-mount the adjustment knob onto the belt conveyor speed control shaft, and tighten the setscrew so that the KNOB indicating mark is pointing at the number “6” on the surrounding label.
- G. The conveyor belt is now calibrated for ALL ranges as indicated on the label. The label numbers are COOK TIME in MINUTES. Simply point the knob indicating line to the desired cook time.  
**NOTE:** The label COOK TIME marks are close approximates, and may vary slightly from actual timing results using the method described.
- H. Cook/Bake Time is not the same as time of delivery. **Time of Delivery** is the actual time required for the first item, leading edge to trailing edge. **Cook/Bake Time** is leading edge to leading edge. For example, the **Time of Delivery** for a 16” pizza with a 6 minute **Bake/Cook Time** (using the DualAir 1828 conveyor) is 9.4 minutes.

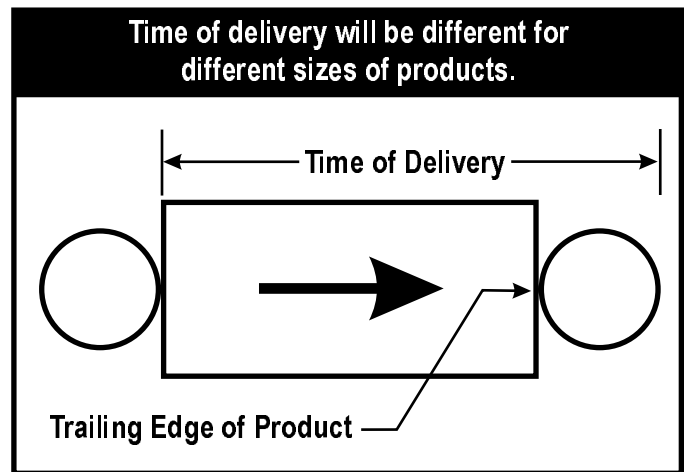
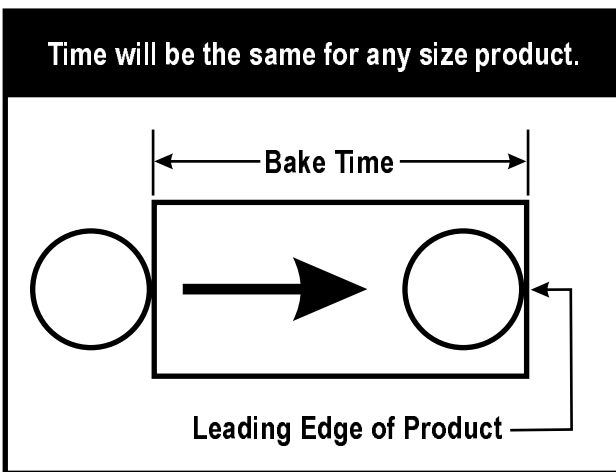

$$\text{Time of Delivery (TOD)} = \frac{\text{Bake Time}}{\text{Bake Chamber Length}} \times (\text{Bake Chamber Length} + \text{Product Diameter})$$

**Example:**

Bakers Pride Dual Air Model 1828, 6 Minute Bake Time, 16” pizza (time required for the 1st item):

$$\text{(TOD)} = \frac{6 \text{ Minutes}}{28"} \times (28 + 16) = 9.4 \text{ Minutes}$$

- I. To calculate production capacity per conveyor, per hour use the following formula.

$$\text{Oven Capacity/Hour (OCH)} = \frac{\text{Bake Chamber Length} \times \text{Bake Chamber Depth}}{\text{Product Diameter}^2} \times \frac{60 \text{ Min/Hr}}{\text{Bake Time}}$$

**Example:**

Bakers Pride Dual Air Model 1828, 6 Minute Pizza, 16” Pizza

$$\text{OCH} = \frac{(28 \times 18)}{16^2} \times \frac{60}{6} = 19.7$$

## 19. TROUBLESHOOTING GUIDE

THE PROBLEM	THE CAUSE	THE SOLUTION
Oven doesn't start	Blown fuse	Replace fuse with identical type - 10 amp
	Main Switch OFF	Turn ON
	Main Switch broken	Replace
	Main circuit breaker OFF	Turn ON
	Power cord disconnected	Plug cord in
	Power connections broken	Check power distribution terminal block below Power Control Box
Conveyor belt doesn't move, or it moves unevenly. Unexpected speed changes.	Conveyor belt running backwards	<b>CAUTION: TURN OFF POWER</b> , open Power Control Box, and flip Reversing Switch to opposite position.
	Belt loose. Drive sprockets not engaging belt links.	Tighten conveyor belt using adjustable tensioner at one end of belt frame.
		Verify that all sprockets are tight and properly aligned with belt "segments".
		If belt still too loose, remove one belt link.
	Belt master link(s) missing, broken, or installed incorrectly.	Install master link(s) properly
	Speed setting very high (long cook time)	Adjust speed to FAST to verify if knob is tight and potentiometer working correctly
	Speed knob loose	Tighten setscrew in knob on pot shaft. <b>NOTE:</b> Mark on knob should line up with mark on label to indicate cook time in minutes. This may require calibration of belt movement using timing marks on conveyor frame. <b>For CALIBRATION, see Section 18.</b>
	Conveyor drive shaft not engaged to coupling	Align and engage shaft pin to slot in drive coupling
	Drive coupling loose	Tighten setscrew to gearmotor output shaft (shaft is "flatted" for setscrew grip)
	Drive coupling missing	Properly re-attach and tighten to gearmotor output shaft
	Conveyor belt jammed	Remove belt assembly to identify obstruction to belt movement. Remedy problem. Straighten bent belt links
	Drive shaft pin missing	Locate and re-install or replace
	Drive sprockets worn out, missing, or mis-aligned	Replace sprockets or entire drive shaft assembly. Tighten sprockets to shaft.
Conveyor gearmotor failed	<b><u>CAUTION: THE FOLLOWING TESTS ARE PERFORMED WITH LIVE POWER WITH CONTROL BOX OPEN. THESE TESTS TO BE PERFORMED ONLY BY AN AUTHORIZED SERVICE AGENT.</u></b> 1. Test by disconnecting conveyor belt. If no shaft rotation or motor noise when power applied, test power supply. 2. Test power supply input connections @ terminal block (85-265 VAC). 3. Remove cover from power supply enclosure and verify integrity of internal connections (Molex pin connectors).	

THE PROBLEM	THE CAUSE	THE SOLUTION
Conveyor belt doesn't move, or it moves unevenly. Unexpected speed changes. (Continued)	Conveyor gearmotor failed (Continued)	4. Verify wire connectors from power supply to gearmotor (2 wires w/connectors). If power supply doesn't give 24 VDC output, replace it. 5. Verify potentiometer connections to gearmotor (3 wires w/connectors). If speed doesn't change when knob is turned, test with spare pot before replacing original pot. If all previous tests verify power and control to gearmotor, replace gearmotor.
No air or not enough air coming from blower(s)	Blower motor(s) "stalled" (not running when Main Switch ON)	Turn Main Switch OFF for at least 30 seconds, then turn it ON again. This resets speed controls. If this doesn't help, turn OFF Main Circuit Breaker for 1 Minute, then turn it ON again.
	Blower motor(s) "jammed"	Remove source(s) of obstruction. <b>CAUTION: TURN OFF MAIN CIRCUIT BREAKER BEFORE REACHING INTO BLOWER WHEEL COMPARTMENT. SERIOUS INJURY COULD RESULT OTHERWISE!!</b> <b>CAUTION: THE FOLLOWING TESTS 1-5 ARE PERFORMED WITH LIVE POWER WITH CONTROL BOX OPEN, OR REAR MOTOR COVER REMOVED. THESE TESTS TO BE PERFORMED ONLY BY AN AUTHORIZED SERVICE AGENT.</b>
	Wire connections broken or loose between blower motor(s) and terminal block.	Insure these (3) wires are tight on terminal block located in blower motor compartment.
	Blower motor(s) failed	If all previous tests are normal, then blower motor has failed. Replace.
Oven not hot enough	Temperature setting too low	Turn temperature control knob to right (clockwise)
	Cooking too soon	Oven takes 30-40 minutes to get up to stabilized operating temperature.
	Temperature control not working properly	Turn temperature knobs back and forth. Do both lights go ON & OFF? If YES, then temperature controls are OK. If NO, then malfunctioning light indicates which control needs further investigation. Use the following steps to check. <b>CAUTION: THE FOLLOWING TESTS ARE PERFORMED WITH LIVE POWER WITH CONTROL BOX OPEN. THESE TESTS TO BE PERFORMED ONLY BY AN AUTHORIZED SERVICE AGENT.</b>

THE PROBLEM	THE CAUSE	THE SOLUTION
Oven not hot enough (Continued)	Temperature control not working properly (Continued)	<ol style="list-style-type: none"> <li>1. Locate the two temperature controls mounted with power control box on the hinged door, near the cooling fan. Verify that ALL connections and connectors are properly fastened and tight. Power should be connected to terminals labeled 120 &amp; VAC COM.</li> <li>2. Locate the two wires from each of the temperature sensors (top left terminals labeled PROBE). These have braided insulation. Verify their integrity.</li> <li>3. If necessary to test, disconnect one sensor at a time, and use voltmeter to measure resistance at sensor wires. Compare to resistance chart in back of this manual. If sensors show INFINITE resistance, sensor is bad. Replace.</li> <li>4. If resistance reads value within range of chart, sensor is good, control needs further investigation. Re-connect sensor wire leads. (See diagram at back of manual for proper identification of controls). <b>NOTE: temperature sensor lead wires are NOT polarity sensitive, since sensor is an RTD-type.</b></li> <li>5. If both sensors are good, swap sensor leads between controls. Turn temperature knobs ON &amp; OFF. Whichever light works properly, the <b>OPPOSITE</b> control is bad. Replace.</li> </ol>
	Burners not working properly	<p><b>THIS TYPE OF DIAGNOSTICS TESTING CAN ONLY BE PERFORMED BY AN AUTHORIZED SERVICE AGENT.</b></p> <ol style="list-style-type: none"> <li>1. With Main Switch OFF, remove the burner access covers located on the front vertical face of the oven. One top, one bottom. Burner operation can now be observed.</li> <li>2. Turn the oven ON and let it run for 2 minutes, with the temperature settings to <b>maximum</b> heat. Blowers must be working.</li> <li>3. Observe if both top and bottom burners operate properly: flame should be constant and being sucked into blower.</li> <li>4. If both burners are on, run for 10-15 minutes, with temperature control set at 500°F.</li> <li>5. Observe that burners cycle ON &amp; OFF with heat demands (heat indicator light goes ON/OFF).</li> </ol>

THE PROBLEM	THE CAUSE	THE SOLUTION
<p>Oven not hot enough (Continued)</p>	<p>Burner(s) do not light</p>	<p>Check the following items first:</p> <ol style="list-style-type: none"> <li>1. Gas Supply connected.</li> <li>2. Shut-off valve open.</li> <li>3. Pressure regulator set correctly.</li> </ol> <p><b>THE FOLLOWING DIAGNOSTICS TESTING CAN ONLY BE PERFORMED BY AN AUTHORIZED SERVICE AGENT.</b></p> <ol style="list-style-type: none"> <li>1. Determine if both burners light on call for heat. <ol style="list-style-type: none"> <li>A. Remove one of two screws that attach burner access covers, located on front vertical face of oven, one top, one bottom.</li> </ol> </li> <li>2. If both burners operate properly, they will cycle ON/OFF at any temperature setting.</li> <li>3. If either burner fails to light, problem could be gas related or electrical related. <b>CAUTION: THE FOLLOWING TESTS ARE PERFORMED WITH LIVE POWER WITH GAS CONTROL BOX OPEN. THESE TESTS TO BE PERFORMED ONLY BY AN AUTHORIZED SERVICE AGENT.</b></li> <li>4. At burner access holes, verify the burner assembly is grounded (green wire, ring terminal to burner support bracket).</li> <li>5. At same burner access holes, verify 3-wire harness is properly connected.</li> <li>6. At Gas Control Box, verify each 3-wire burner harness is properly connected to 12-pole terminal block.</li> <li>7. At 12-pole terminal block, verify all wires are tight by exerting small pull on each wire.</li> <li>8. If one burner lights, determine which ignition module is operating properly, and swap 7-wire ignition harnesses between modules. Check if burner ignition problem follows ignition module.</li> <li>9. To verify if gas valve is operating correctly, swap ignition module wires from one valve to another, observing if burner ignition problem changes burners.</li> <li>10. By steps 8 &amp; 9, it should be possible to determine if ignition module is good. Replace any module that is defective.</li> <li>11. Verify that temperature control inputs are correct &amp; tight at 12-pole terminal block.</li> <li>12. Verify that vacuum switch wires are in tact and that plastic hoses are connected.</li> <li>13. Verify that transformers are wired correctly and operating properly.</li> <li>14. If either gas valve is defective, replace.</li> <li>15. If both ignition modules are good, and any ignitor fails to glow at call for heat, re-check wiring at 12-pole terminal block before replacing ignitor.</li> <li>16. If burner ignites, but flame goes out in a few seconds, re-check wiring at 12-pole terminal block before replacing flame sensor.</li> </ol>

## 20. TEMPERATURE CONTROL CONVERSION CHART - OHMS TO DEGREES

The temperature sensor (probe) that is supplied with this conveyor oven is an RTD type, which yields an output based on Ohms of resistance. This particular RTD device has a linear resistance curve that produces a very predictable amount of resistance that can be converted to degrees Fahrenheit. This particular device produces a resistance increase of 2 Ohms per every 1 degree F. The baseline value is approx. 1000 ohms at 32 °F (0°C).

Ohms	°F	Ohms	°F	Ohms	°F
1002	32	1411	230	1813	430
1004	34	1420	234	1821	434
1017	40	1432	240	1832	440
1025	44	1440	244	1844	446
1038	50	1452	250	1852	450
1046	54	1460	254	1860	454
1059	60	1473	260	1872	460
1067	64	1481	264	1879	464
1080	70	1493	270	1891	470
1088	74	1501	274	1899	474
1101	80	1513	280	1911	480
1109	84	1521	284	1918	484
1122	90	1533	290	1930	490
1130	94	1541	294	1938	494
1143	100	1554	300	1950	500
1151	104	1562	304	1957	504
1164	110	1574	310	1969	510
1172	114	1582	314	1977	514
1184	120	1594	320	1988	520
1193	124	1602	324	1996	524
1205	130	1614	330	2008	530
1214	134	1622	334	2027	540
1226	140	1634	340	2035	544
1234	144	1642	344	2046	550
1247	150	1654	350	2054	554
1255	154	1662	354	2066	560
1267	160	1674	360	2073	564
1276	164	1682	364	2085	570
1288	170	1694	370	2093	574
1286	174	1702	374	2105	580
1309	180	1714	380	2112	584
1317	184	1722	384	2124	590
1329	190	1734	390	2132	594
1338	194	1742	394	2144	600
1350	200	1753	400	2151	604
1358	204	1761	404	2163	610
1370	210	1773	410	2171	614
1379	214	1781	414	2182	620
1391	220	1793	420	2190	624
1399	224	1801	424	2202	630

# 21. ELECTRICAL SCHEMATIC & WIRING DIAGRAM

## VH 1828G ELECTRICAL SCHEMATIC 115VAC, 50/60Hz, 1 Phase

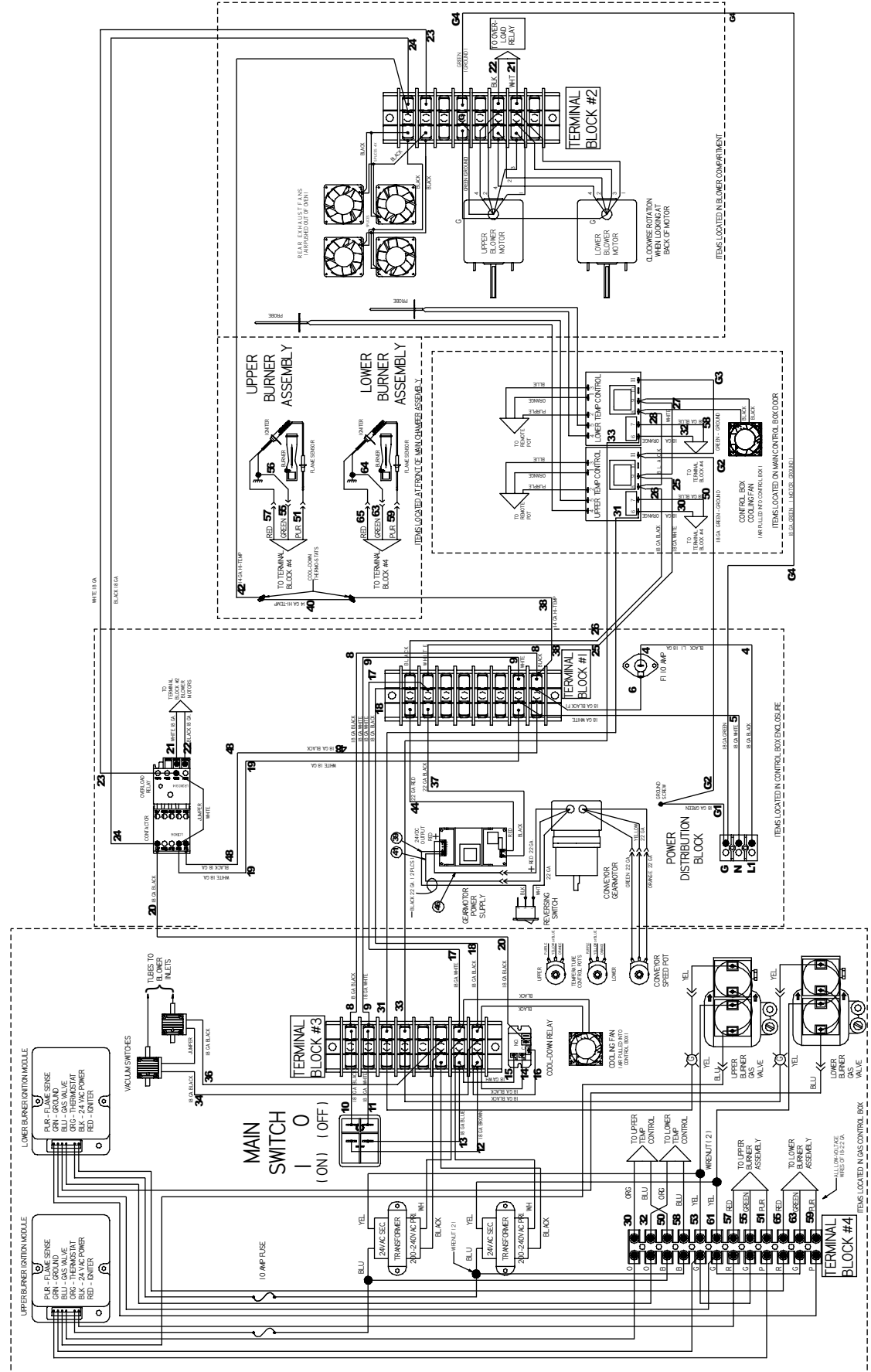

U4182Q

# VH 1828G WIRING DIAGRAM 115VAC, 50/60Hz, 1 Phase

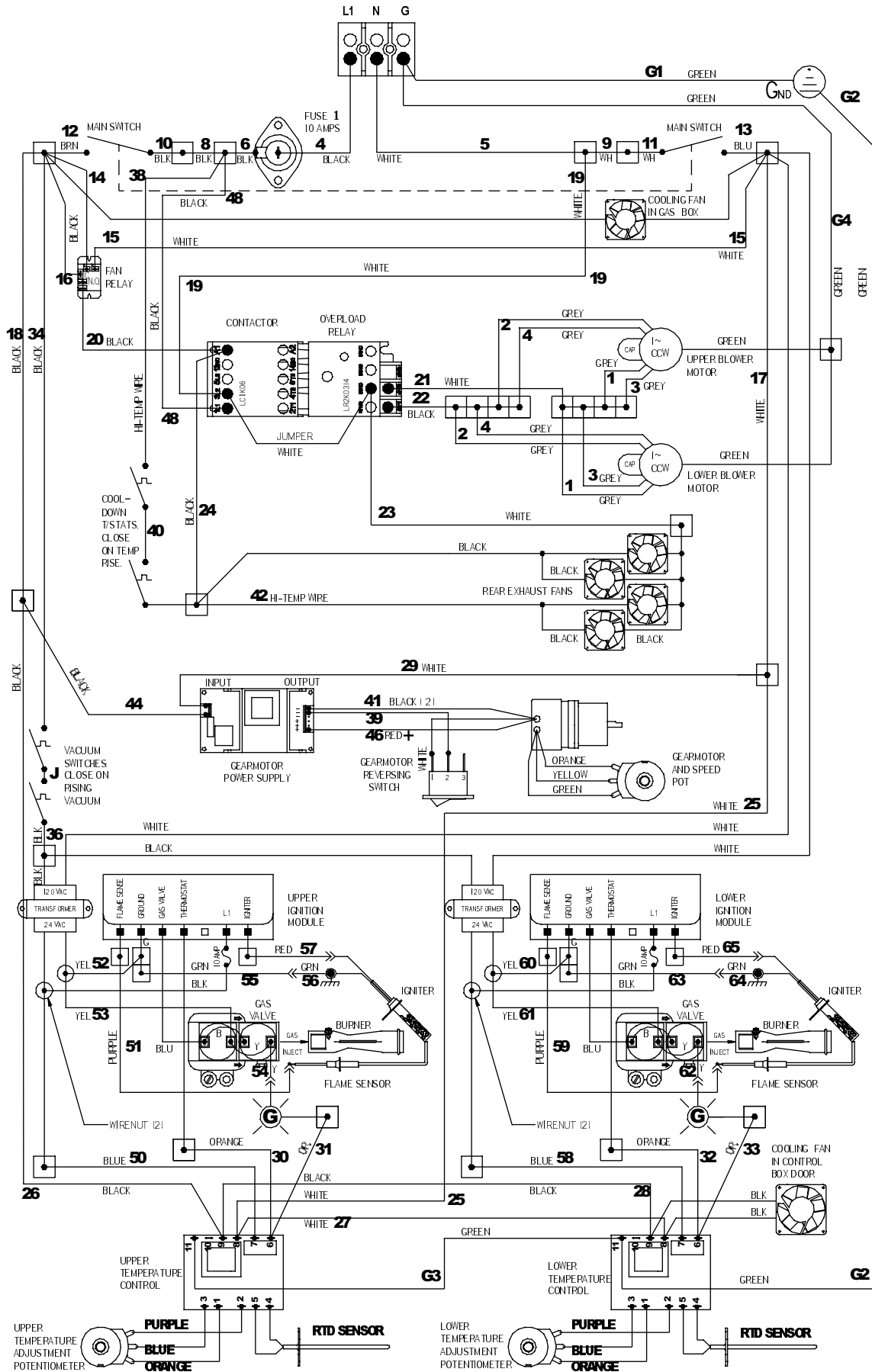



## 22. PARTS LISTS & EXPLODED VIEWS

**Figure "A" External Covers**

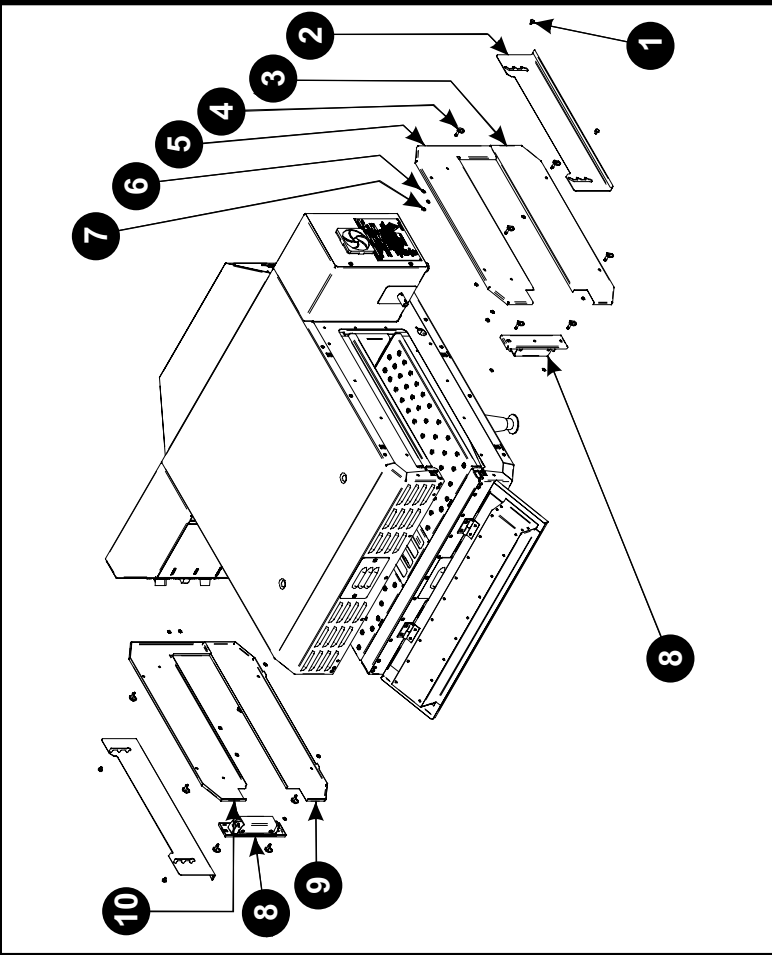

Item	P/N	Description	Quan
1	S3225A	HANGER PIN	4
2	B6051K	ADJUSTABLE BAFFLE	2
3	B6336K	OUTER LOWER COVER, RIGHT	1
4	Q4043A	1/4-TURN FASTENER	12
5	B6335K	OUTER UPPER COVER, RIGHT	1
6	Q4044A	RETAINING RING (for Item #4)	12
7	Q1499A	LOCKNUT (for Item #1)	4
8	S6266U	REMOVABLE FRAME SPREADER	2
9	B6343K	OUTER LOWER COVER, LEFT	1
10	B6342K	OUTER UPPER COVER, LEFT	1

**Figure "B" Conveyor Assembly**

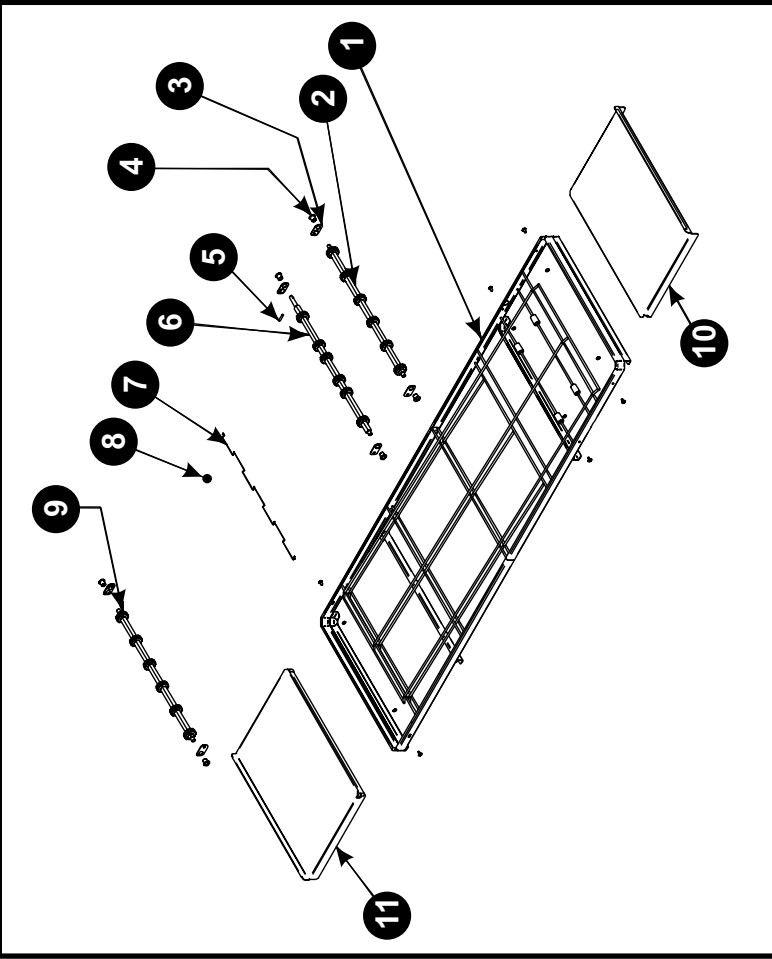

Item	P/N	Description	Quan
1	B6345T	COMPLETE CONVEYOR ASSY WITH WIRE BELT	1
2	S3266U	IDLER SHAFT ASSY (COMPLETE W/SPROCKETS)	2
3	B6068U	BEARING CLIP ASSEMBLY	6
4	S3254A	PLASTIC BEARING	6
5	Q4045A	DRIVE PIN IN DRIVE SHAFT	1
6	S3267U	DRIVE SHAFT ASSY (COMPLETE W/SPROCKETS)	1
7	S3253A	COMPLETE WIRE BELT ASSEMBLY	1
8	S3259A	WIRE BELT MASTER LINK (NOT SHOWN)	2
9	S3270A	METAL SPROCKET	18
10	B6087U	DISCHARGE EXTENSION TRAY	1
11	B6089U	INFEED EXTENSION TRAY	1

**Figure "C" Blower Motor Cover Assembly**

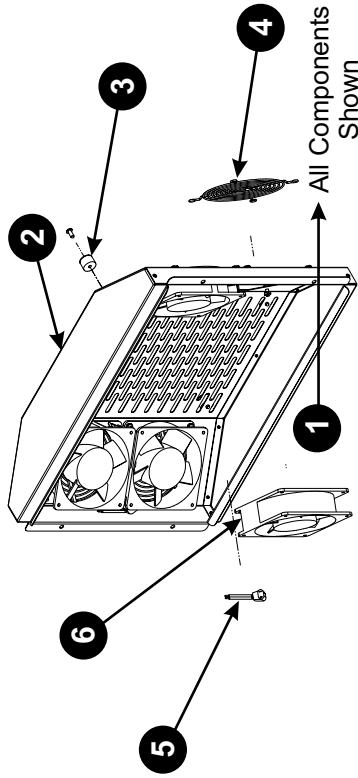

Item	P/N	Description	Quan
1	B6323T	COMPLETE REAR BLOWER MOTOR COVER ASSY ( ITEMS 2-6 )	1
2	B6219U	REAR BLOWER MOTOR COVER	1
3	S1392A	RUBBER BUMPER	4
4	Q1504A	FAN GUARD	4
5	P6471A	FAN CORD ASSY	2
6	M1193A	COOLING FAN, 115V	4

**Figure "D" Blower Assembly**

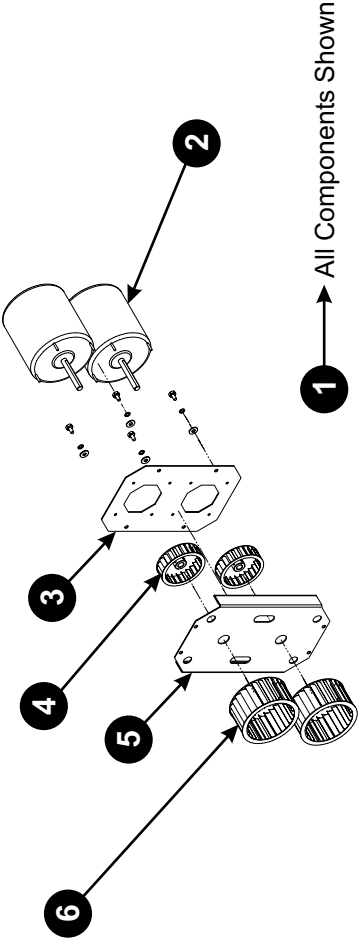

Item	P/N	Description	Quan
1	M1548U	COMPLETE BLOWER MOTOR ASSY ( ITEMS 2-6 )	1
2	M1548A	BLOWER MOTOR, 1/4 HP, 115/230 V, 1 PH	2
3	B6031K	MOTOR MOUNT PLATE	1
4	S3260A	HEAT SLINGER WHEEL	2
5	B6027K	MOTOR MOUNT BRACKET ASSY	1
6	M1510A	MAIN BLOWER WHEEL	2

**Figure "E" VH Series Ovens Only**

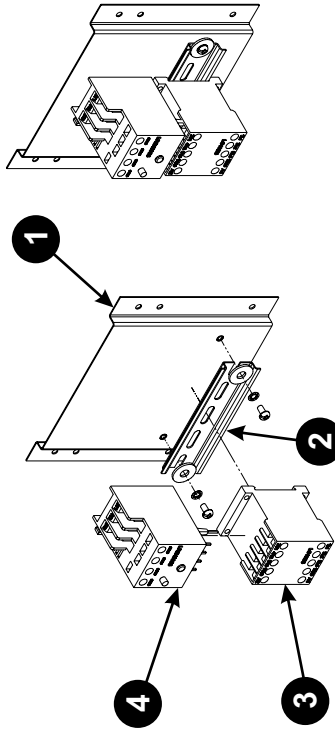

Item	P/N	Description	Quan
1	B6086U	MOUNT BRACKET ASSY	1
2	P1150Z	DIN RAIL	1
3	M1385A	CONTACTOR, 15A, 3-POLE, 115V	1
4	M1386A	OVERLOAD RELAY	1

**Figure "F" Plenum "Finger" Assembly**

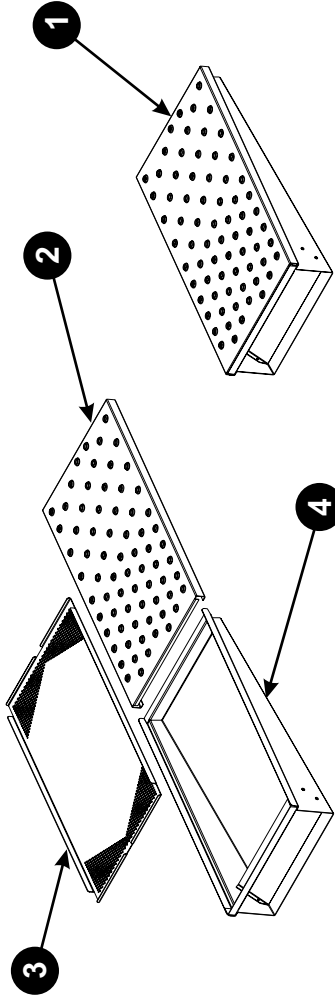

Item	P/N	Description	Quan
1	B6221T	COMPLETE PLENUM "FINGER" ASSY ( ITEMS 2-4 )	4
2	B6225K	OUTER EXTRUDED-HOLE PANEL	4
3	B6226K	INNER PERFORATED PANEL	4
4	B6222U	MAIN BODY PANEL	4

Figure "G" Main Power Control Box

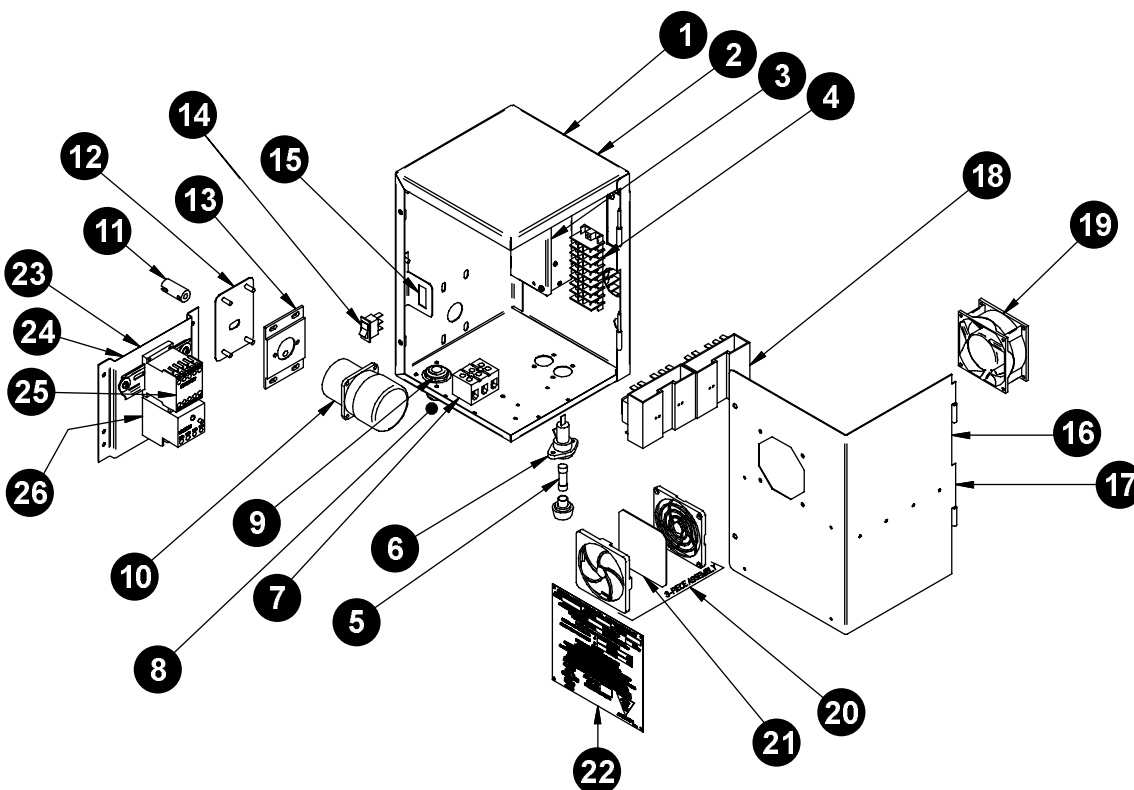

Item	P/N	Description	Quan
1	B6319T	MAIN CONTROL BOX ASSY ( ITEMS 2-24)	1
2	B6319U	MAIN CONTROL BOX ASSY (BARE)	1
3	B6090U	GEARMOTOR POWER SUPPLY ASSY	1
4	P1170A	TERMINAL BLOCK, 8-POLE	2
5	P1196A	FUSE, 10A	1
6	P1064A	FUSEHOLDER ( WITH TWIST CAP, MINUS FUSE )	1
7	P1003A	POWER TERMINAL BLOCK, 3-POLE	1
8	P6004A	POWER CORD ( NOT SHOWN) 15 A, 300V, 14/3	1
9	P1006A	STRAIN RELIEF	1
10	M1501A	GEARMOTOR - CONVEYOR BELT DRIVE	1
11	S3262A	GEARMOTOR DRIVE COUPLING	1
12	B6074U	GEARMOTOR ADJUSTMENT PLATE	1
13	S3263A	GEARMOTOR ADAPTER PLATE	1
14	M1307A	GEARMOTOR REVERSING SWITCH	1
15	B6079K	REVERSING SWITCH MOUNT BRACKET	1
16	B6309T	HINGED DOOR ASSY ( ITEMS 17-22 )	1
17	B6309U	HINGED DOOR ASSY (BARE)	1
18	M1545A	TEMPERATURE CONTROL, 115V, 150 - 600°F	2
19	M1235A	COOLING FAN, 115V	1
20	M1549A	COOLING FAN FILTER/GUARD ( 3 PIECE ASSY )	1
21	M1550A	FILTER MEDIA ( PKG OF 5 )	1
22	U1062A	RATING PLATE	1
23	B6341T	MOTOR STARTER ASSY ( ITEMS 24-26 )	1
24	B6086U	CONTACTOR MOUNT BRACKET ASSY	1
25	M1386A	OVERLOAD RELAY	1
26	M1385A	CONTACTOR, 15A, 3-POLE, 115V	1

Figure "H" Gas Control Box

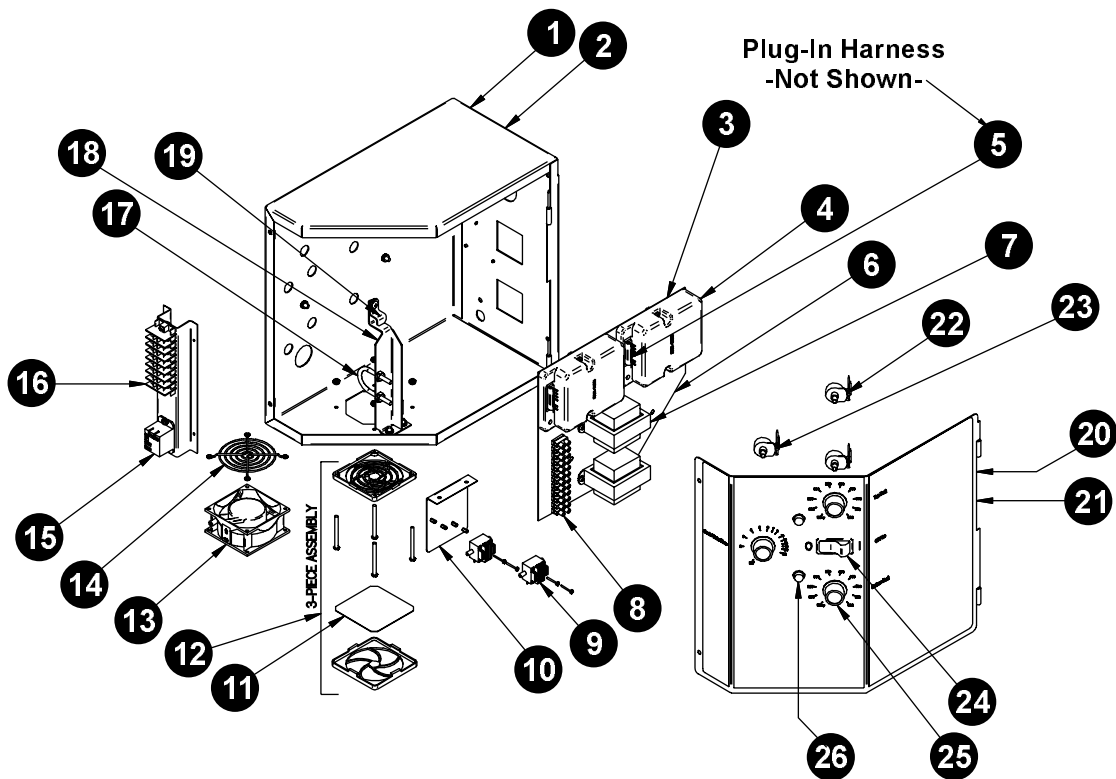

Item	P/N	Description	Quan
1	B6325T	MAIN GAS BOX ASSY ( ITEMS 2-18 )	1
2	B6325U	MAIN GAS BOX (BARE)	1
3	B6333U	GAS IGNITION SYSTEM MOUNT SUBPLATE ASSY ( ITEMS 4-8 )	1
4	M2138A	GAS IGNITION MODULE, 24V	2
5	M2139A	IGNITION MODULE 6-WIRE HARNESS (NOT SHOWN)	2
6	B6333K	GAS IGNITION SYSTEM MOUNT SUBPLATE	1
7	M1360A	TRANSFORMER, 120/240/24VAC	2
8	P1176A	TERMINAL BLOCK, 12-POLE	1
9	M1546A	VACUUM SWITCH	2
10	B6337K	VACUUM SWITCH MOUNT BRACKET	1
11	M1550A	FILTER MEDIA ( PKG OF 5 )	1
12	M1549A	COOLING FAN FILTER/GUARD ( 3 PIECE ASSY )	1
13	M1235A	COOLING FAN, 115V	1
14	M1524A	COOLING FAN INNER GUARD, METAL	1
15	M1544A	COOL-DOWN RELAY, 115V	1
16	P1170A	TERMINAL BLOCK, 8-POLE	1
17	Q2056A	"U" BOLT (MANIFOLD CLAMP)	1
18	B6330U	GAS MANIFOLD MOUNT BRACKET	1
19	B6331K	PIPE CLAMP	1
20	B6327T	HINGED DOOR ASSY ( ITEMS 21-26 )	1
21	B6327U	HINGED DOOR ASSY (BARE)	1
22	M1505A	POTENTIOMETER (AIR TEMPERATURE CONTROL)	2
23	M1519A	POTENTIOMETER (BELT CONVEYOR SPEED CONTROL)	1
24	M1352A	MAIN ON/OFF SWITCH	1
25	S1205A	ADJUSTMENT KNOB	3
26	P1204A	INDICATOR LIGHT, GREEN	2

**Figure "I" Cool-Down Thermostat, Elements, Switch & Probe**

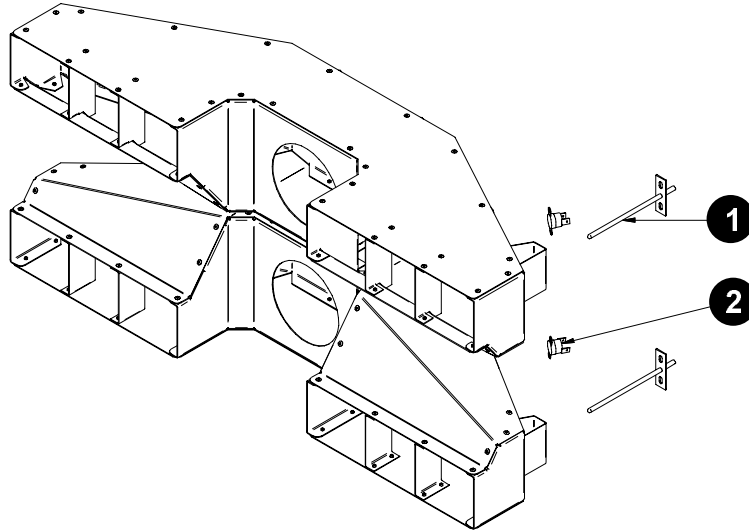

Item	Part Number	Description	Quan
1	M1518A	TEMPERATURE SENSOR PROBE	2
2	M1534A	COOL-DOWN THERMOSTAT	2

**Figure "J" Gas Burner Assembly**

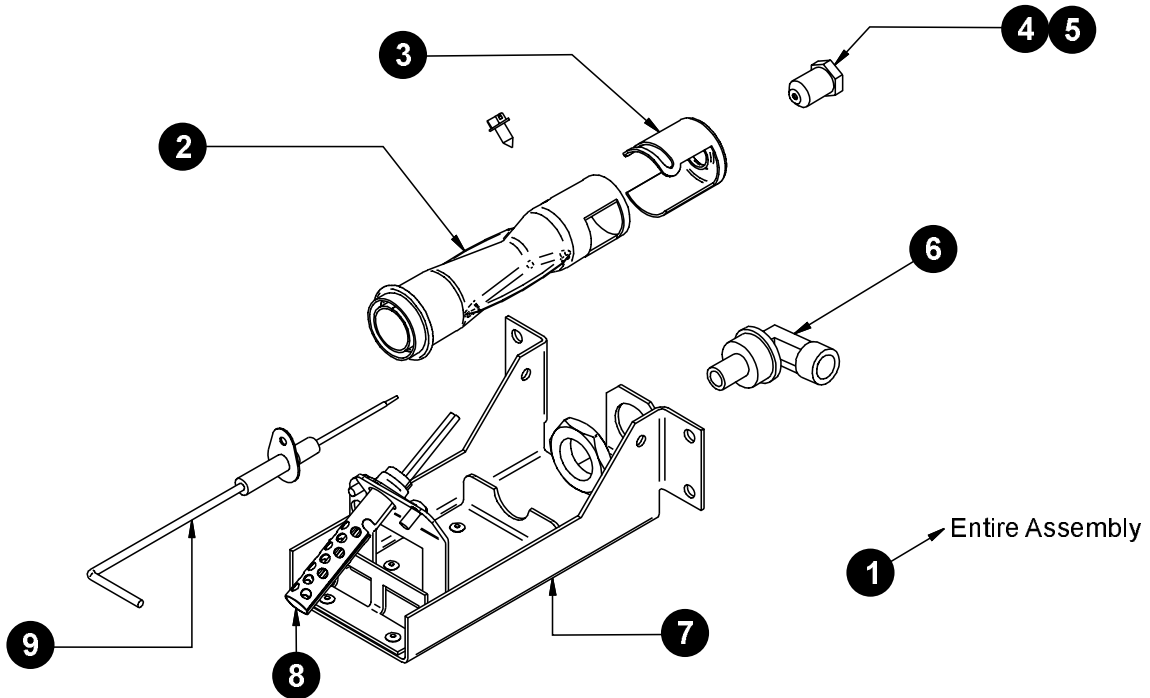

Item	Part Number	Description	Quan
1	B6318U	BURNER ASSY, 25K BTU/HR ( ITEMS 2-9 )	1
2	L5106A	GAS BURNER ASSY (MINUS AIR SHUTTER)	1
3	N5876A	ADJUSTABLE AIR SHUTTER	1
4	R3224P	ORIFICE HOOD, #43, NATURAL GAS	1
5	R3245P	ORIFICE HOOD, #53, PROPANE GAS	1
6	N3084A	BRASS ELBOW FITTING ( ORIFICE HOOD MOUNT)	1
7	B6318K	BURNER ASSY MOUNT BRACKET	1
8	M2140A	GAS IGNITER ELECTRODE	1
9	M1167A	FLAME SENSOR	1

**Figure "K" Gas Manifold System**

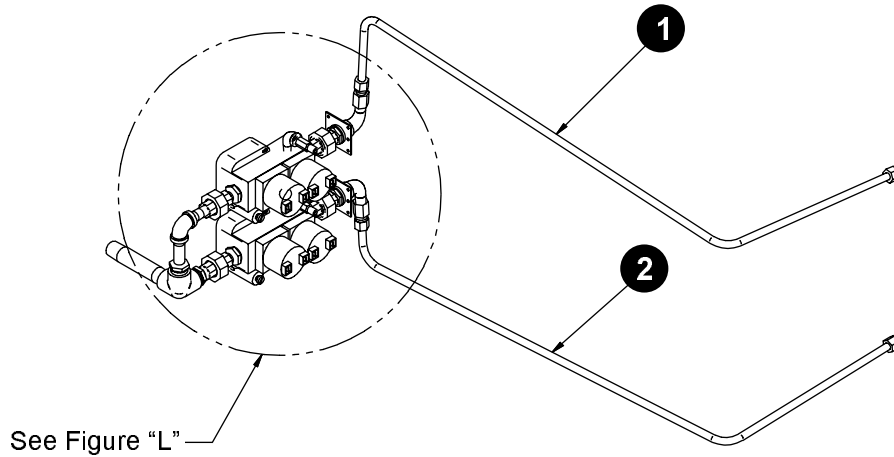

Item	Part Number	Description	Quan
1	R5877A	UPPER GAS MANIFOLD TUBE	1
2	R5878A	LOWER GAS MANIFOLD TUBE	1

**Figure "L" Gas Valve Assembly**

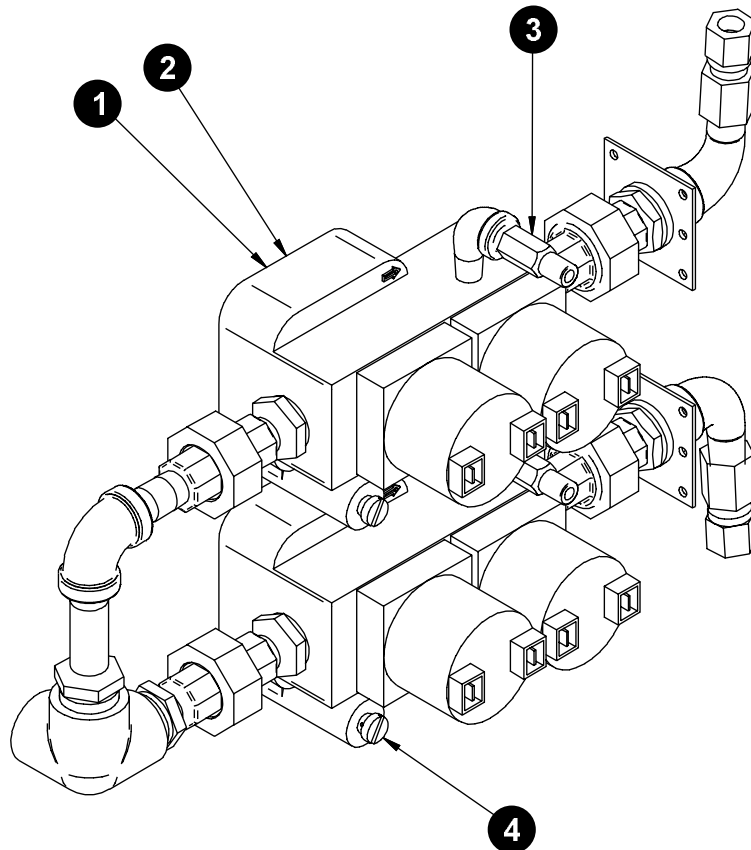

Item	Part Number	Description	Quan
1	R3225A	GAS VALVE ASSEMBLY, NATURAL GAS	2
2	R3227P	GAS VALVE ASSEMBLY, PROPANE GAS	2
3	N3068P	PRESSURE NOZZLE	2
4	R3226A	CONVERSION KIT ( NAT. GAS TO L.P.)	2



## 23. BAKERS PRIDE LIMITED WARRANTY

30 Pine Street New Rochelle, New York 10801  
914 / 576 - 0200 ? US & Canada: 1 - 800 - 431 - 2745 ? fax 914 / 576 - 0605

- WHAT IS COVERED** This warranty covers defects in material and workmanship under normal use, and applies only to the original purchaser providing that:
- \* The equipment has not been accidentally or intentionally damaged, altered or misused;
  - \* The equipment is properly installed, adjusted, operated and maintained in accordance with National and local codes, and in accordance with the installation instruction provided with the product;
  - \* The serial number rating plate affixed to the equipment has not been defaced or removed.
- WHO IS COVERED** This warranty is extended to the original purchaser and applies only to equipment purchased for use in the U.S.A.
- COVERAGE PERIOD** Full size gas and electric deck ovens: Two (2) year limited parts and labor: Cyclone Convection Ovens: BCO Models: One (1) Year limited parts and labor; GDCO Models: Two (2) Year limited parts and labor; CO II Models: Two (2) Year limited parts and labor; (5) Year limited door warranty.  
All Other Products: One (1) Year limited parts and labor.  
Warranty period begins the date of dealer invoice to customer or ninety (90) days after shipment date from BAKERS PRIDE - whichever comes first.
- WARRANTY COVERAGE** This warranty covers on-site labor, parts and reasonable travel time and travel expenses of the authorized service representative up to (100) miles, round trip, and (2) hours travel time. The purchaser, however, shall be responsible for all expenses related to travel, including time, mileage and shipping expenses on smaller counter models that may be carried into a Factory Authorized Service Center, including the following models: PX-14, PX-16, PI8, and BK-18.
- EXCEPTIONS** All removable parts in BAKERS PRIDE Char-broilers, including but not limited to: Burners, Grates, Radiants, Stones and Valves, are covered for a period of SIX MONTHS.  
All Ceramic Baking Decks are covered for a period of THREE MONTHS. The installation of these replacement decks is the responsibility of the purchaser.  
The extended Cyclone door warranty years 3 through 5 is a parts only warranty and does not include labor, travel, milage or any other charges.
- EXCLUSIONS**
- \* Negligence or acts of God,
  - \* Thermostat calibrations after (30) days from equipment installation date,
  - \* Air and Gas adjustments,
  - \* Light bulbs,
  - \* Glass doors and door adjustments.
  - \* Fuses.
  - \* Char-broiler work decks and cutting boards,
  - \* Tightening of conveyor chains,
  - \* Adjustments to burner flames and cleaning of pilot burners,
  - \* Tightening of screws or fasteners.
  - \* Failures caused by erratic voltages or gas supplies,
  - \* Unauthorized repair by anyone other than a BAKERS PRIDE Factory Authorized Service Center,
  - \* Damage in shipment,
  - \* Alteration, misuse or improper installation,
  - \* Thermostats and safety valves with broken capillary tubes.
  - \* Accessories - spatulas, forks, steak turners, grate lifters, oven brushes, scrapers, peels, Etc.,
  - \* Freight - other than normal UPS charges,
  - \* Ordinary wear and tear.
- INSTALLATION** Leveling and installation of decks, as well as proper installation and check out of all new equipment - per appropriate installation and use materials - is the responsibility of the dealer or installer, not the manufacturer.
- REPLACEMENT PARTS** BAKERS PRIDE genuine Factory OEM parts receive a (90) day materials warranty effective from the date of installation by a BAKERS PRIDE Factory Authorized Service Center.

This Warranty is in lieu of all other warranties, expressed or implied, and all other obligations or liabilities on the manufacturers part. BAKERS PRIDE shall in no event be liable for any special, indirect or consequential damages, or in any event for damages in excess of the purchase price of the unit. The repair or replacement of proven defective parts shall constitute a fulfillment of all obligations under the terms of this warranty.

Form #U4177A 1/07



**BAKERS PRIDE OVEN CO., INC.**

30 Pine Street  
New Rochelle, NY 10801

+1 (914) 576-0200 Phone  
+1 (914) 576-0605 Fax

(800) 431-2745 US & Canada  
[www.bakerspride.com](http://www.bakerspride.com) WebAddress  
[info@bakerspride.com](mailto:info@bakerspride.com) e-mail Address